

TAIE

FA series



Digital PID Temperature/Process Controllers Operation Manual



FY/FU Series

CONTENT

| | | |
|-------|---|----|
| 1. | Notice before start-up | 3 |
| 2. | FU Series..... | 4 |
| 2.1 | Specifications..... | 4 |
| 2.2 | Outer Dimension..... | 5 |
| 2.3 | Terminal Wiring Diagram | 6 |
| 2.4 | Assembly & Wiring | 7 |
| 3 | FY Series | 8 |
| 4. | Terminal arrangement..... | 11 |
| 4.1 | FY400 / FU48 Terminals (48mm x 48mm , DIN 1/16)..... | 11 |
| 4.2 | FY600 Terminals (96mm x 48mm , DIN 1/8)..... | 12 |
| 4.3 | FY700 / FU72 Terminals (72mm x 72mm)..... | 13 |
| 4.4 | FY800 / FU86 Terminals (48mm x 96mm , DIN 1/8)..... | 14 |
| 4.5 | FY900 / FU96 Terminals (96mm x 96mm , DIN 1/4)..... | 15 |
| 4.6 | FY100 Terminals (175mm x 110mm)..... | 16 |
| 4.7 | FY101 Terminals (90mm x 90mm)..... | 17 |
| 5. | External dimension and panel cutout 〈 Unit : mm 〉 | 18 |
| 5.1 | FY100..... | 18 |
| 5.2 | FY101..... | 18 |
| 5.3 | FY400~900 & FU48~96..... | 19 |
| 6. | Parts description | 20 |
| 7. | Operations | 21 |
| 7.1 | Power On..... | 21 |
| 7.2 | Change the Set Value (SV)..... | 21 |
| 7.3 | Change the Alarm Value | 21 |
| 7.4 | Autotuning (AT)..... | 22 |
| 7.5 | Programmable RAMP / SOAK (Only available for PFY model) | 23 |
| 8. | Operation levels..... | 24 |
| 8.1 | Levels diagram | 24 |
| 8.2 | Lock function | 24 |
| 9. | Parameters | 25 |
| 9.1 | Level 1 (User Level) | 25 |
| 9.2 | Level 2 (PID Level)..... | 26 |
| 9.2.1 | Level 2 parameters display / hiding condition | 26 |
| 9.2.2 | Description of parameters..... | 27 |
| 9.3 | Level 3 (Input Level)..... | 28 |
| 9.4 | Level 4 (SET level) | 30 |
| 9.4.1 | How to hide parameters (Use SET1~SET7)..... | 30 |
| 9.4.2 | Special functions (Use SET8 / SET9 / SET0) | 31 |
| 9.4.3 | Remote SV type selection | 32 |
| 9.4.4 | Output mode selection (Use OUTY) | 32 |
| 9.4.5 | Modify caution | 32 |
| 9.5 | Program Level (Only displayed in programmable controller) | 33 |
| 9.5.1 | Description of parameters..... | 33 |

| | | |
|--------|--|----|
| 9.5.2 | Description of operation..... | 34 |
| 10. | Input type table (INP1 selection)..... | 35 |
| 11. | Alarm | 37 |
| 11.1 | Alarm time (ALT1/ALT2/ALT3) | 37 |
| 11.2 | SETA..... | 37 |
| 11.3 | Alarm mode (ALD1 / ALD2 / ALD3)..... | 38 |
| 12 | Heater Break Alarm (HBA)..... | 39 |
| 12.1 | HBA Wiring Example | 39 |
| 12.2 | HBA Function Description..... | 39 |
| 12.3 | HBA setting procedure..... | 40 |
| 12.4 | Parameters for HBA function | 40 |
| 12.5 | Activated conditions of HBA | 41 |
| 12.6 | Remarks | 41 |
| 12.7 | CT specifications | 42 |
| 12.7.1 | SC-80T Specifications | 42 |
| 12.7.2 | SC-100T Specifications | 42 |
| 11.7.3 | SC-80T Linear Diagram | 43 |
| 13. | Error codes | 44 |
| 14. | Modify input type ("TC" "RTD")..... | 45 |
| 14.1 | FY400~FY900 | 45 |
| 14.2 | FU48~96..... | 46 |
| 14.3 | FY100~FY101 | 46 |
| 15. | Modify input type : Linear Input (mA ,V)..... | 48 |
| 15.1 | FY400~900 & FU48~96 Hardware : | 48 |
| 15.2 | FY100/101 Hardware : | 49 |
| 15.3 | Calibration : | 50 |
| 16. | Modify Output type : Relay , SSR , 4~20mA..... | 51 |
| 17. | Modify output mode: OUT1/ALARM, OUT1/OUT2 | 51 |
| 18. | Applications | 52 |
| 18.1 | RAMP & SOAK..... | 52 |
| 18.2 | TTL Communication : SV output and RATE function | 53 |
| 18.3 | 1 ψ Phase angle control (By SCR module)..... | 54 |
| 18.4 | 1 ψ Phase angle control (By TRIAC) | 55 |
| 18.5 | 3 ψ Phase angle control (By DIODE/SCR module) | 56 |
| 18.6 | 1 ψ Zero crossing control (By SCR module)..... | 57 |
| 18.7 | 1 ψ Zero crossing control (By TRIAC) | 58 |
| 18.8 | 3 ψ Zero crossing control (By SCR module)..... | 59 |
| 18.9 | 3 ψ Zero crossing control (By TRIAC) | 60 |
| 18.10 | 3 wires proportional motor valve control | 61 |
| 18.11 | Wiring diagram of PC communication..... | 62 |

1. Notice before start-up

FY series controller has got the CE approvals as below:

LVD : D/N EN61010-1

EMC : EN 55 022 1994 /A1 : 1995/ A2 : 1997

EN 61 000-3-2 : 1995 / -3-3 : 1995

EN 61 000-4-2 : 1995 / -4-3 : 1996 / -4-5 : 1995 / -4-6

1996 / -4-8 : 1993 / -4-11 : 1996/ EN 50 204 : 1995

Please confirm the specification of controller is to totally with your requirement before using it, also read this manual in detail.

Danger

1. Danger! Electric Shock!

DON'T touch AC power wiring terminals when controller has been powered!

Keep the power off until all of the wirings are completed!

Warning

1. Please confirm the AC power wiring to controller is correct, otherwise it would be caused aggravated damage on controller. (FY400 connecting with Pin 1 and 6, FY100/FY101/FY600/700/800/900 with Pin 1 and 2).
2. Be sure to use the rated power supply (AC85~265V or DC24V), otherwise it would be caused aggravated damage on controller.
3. Please confirm wires are connected with correct terminal (Input, Output).
4. Use M3 screw-compatible crimp-on terminals with an insulation sleeve, as shown below

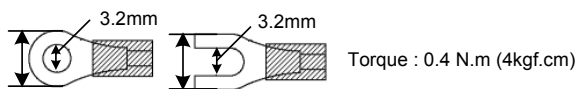

5. Avoid installing controller in following spaces:

- I. A place where the ambient temperature may reach beyond the range from 0 to 50°C
 - II. A place where the ambient humidity may reach beyond the range from 20 to 90% RH.
 - III. A place where the controller likely to come into contact with water, oil, chemicals, steam and vapor.
 - IV. A place where the controller is subject to interface with static electricity, magnetism and noise.
6. For thermocouple (TC) input, use shield compensating lead wire.
 7. For RTD input, use shield wires which have low resistance and no resistance difference between the 3 wires.

2. FA Series

2.1 Specifications

FA module controllers are divided two types FA200 Advance FA211 Economic

| | |
|----------------------------|---|
| FA200 Advance Type | Plug in out terminal, External operating box with double displays |
| FA211 Economic Type | Fixed terminal, Build in 4 operating keys, Single display |

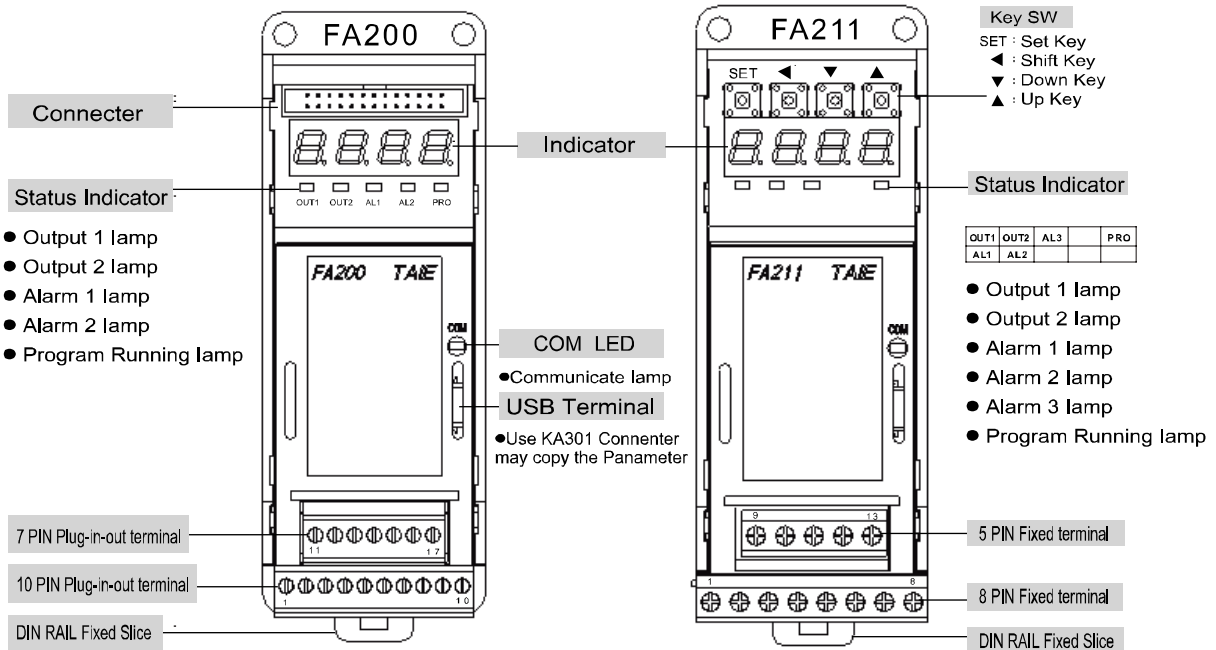

● Standard Spec.

| Model | Advance Type FA200 | Economic Type FA211 | |
|-----------------------|--|---|----|
| Outer case color | two colors of deep black & light gray are available | | |
| Wiring terminal | Plug in out terminal | fixed terminal | |
| Parameter setting | by external control box or by communication | build in 4 operating keys or by communication | |
| Assembly | DIN rail, M4 screw hole, magnetic seat | DIN rail or M4 screw hole | |
| Display | External control box with double display + PV single display | single display | |
| Standard accessories | 1 Output + 1 Alarm | | |
| Maximum expansibility | 1 Output + 2 Alarms or 2 Outputs + 1 Alarm | | |
| Additional Option | Programmable 2 patterns by 8 segments | Yes (Option) | |
| | High life SSR | Yes (Option) | |
| | Communication | Yes (Option) | |
| | Motor Valve Control | Yes (Option) | No |
| | TRS | Yes (Option) | No |
| | Remote SV | Yes (Option) | No |
| | Heater Break Alarm (HBA) | Yes (Option) | No |

● General Spec.

| | | |
|------------------------------------|---|---------------------|
| Supply Voltage | AC 85-265V | |
| Frequency | 50 / 60 HZ | |
| Power Consumption | Approx 4VA | |
| Data Protection | EEPROM, Endurance : 1 Million write cycles, Data Retention : 10 years | |
| Isolated resistance | main loop -case(ground) - control loop - case(ground) DC500V > 10MΩ | |
| Dielectric Strength | main loop -case(ground) AC 1500V 1min / control loop - case(ground) AC 1000V 1min | |
| Vibration Endurance | 10~55HZ 0.5mm (MAX 2G) XYZ various direction 2h | |
| Assault Endurance | 100m/s ² (Approx 10G) XYZ various direction 3 times | |
| Protection Configuration | IP00 | |
| Display Height of Control box | LED Module PV : 14mm SV : 10mm | without control box |
| Display Height of single range LED | 7 section digital display : 7mm | |
| Dimension | 40 x 107 x 43 mm | |
| Weight | Approx x 115g | |
| Operating Ambient temperature | 0~50°C | |
| Operating Ambient humidity | correspondent humidity 20-90% RH without dew | |
| Reserved Temperature | -25°C ~ + 65°C | |

● Control Features

| | |
|-----------------------|---|
| Control method | Heating, Cooling single output or Heating & Cooling both output PID, PI, PD, P, ON/OFF (P=0), FUZZY |
| PID Parameter | P : 0.0 - 200.0% I : 0 ~3600 sec. D : 0 ~900 sec. |
| Control Cycle | 0~150 sec. |

● Input Features

| | | |
|-------------------------------|---|---|
| Input | The point of signal point | 1 point |
| | Accuracy | 0.2 % Full Scale \pm 1digit |
| | Sample time | 250 ms |
| | TC | K, J, R, S, B, E, N, T, W5Re/W26Re, PLII, U, L |
| | RTD | PT100, JPT100 |
| | mA (DC) | 4-20mA, 0-20mA |
| | Voltage (DC) | 0-1V, 0-5V, 0-10V, 1-5V, 2-10V, -10-10mV, 0-10mV, 0-20mV, 0-50mV, 10-50mV |
| | DP Position Option | When using the input of sensor signal, DP position for PV can be selected the sensor code No. 1~ 52 |
| 0000 000.0 00.00 0.000 | When using the input of DC mA or Voltage, DP position for PV can be selected code No. 61 ~96 by DP Parameter. | |

● Output Features

| | | | |
|-----------------|-------------------------------|--|------------------------------|
| Output 1 | Relay | SPDT type (a point 8A, b point 3A 220V) | SPST type (1a point 8A 220V) |
| | For external SSR drive | ON : 24V, OFF : 0V, Max. load current 20mA | |
| | 4-20mA / 0-20mA | Max. load resistance 560 Ω | |
| | 0-5V, 0-10 V | Max. load current 20mA | |
| | SSR high life relay | 1A TRIAC SSR (Option) | |
| Output 2 | Relay | SPST type 8A 220V | |
| | For external SSR drive | ON : 24V, OFF : 0V, Max. load current 20mA | |
| | 4-20mA / 0-20mA | Max. load resistance 560 Ω | |
| | 0-5V, 0-10 V | Max. load current 20mA | |
| | High life relay | 1A TRIAC SSR (Option) | |

● Communication

| | |
|--------------------------|--|
| Interface | RS-485 two wires Half Duplex |
| Protocol | Modbus RTU, Modbus ASCII, TAIE |
| Data bit | 8 bit |
| Start bit | 1 bit |
| Stop bit | 1 bit or 2 bit |
| Baud rate | 38400, 19200, 9600, 4800, 2400 bps \circ |
| Error examine | Parity even, odd or CRC-16 (in Modbus) |
| Connective pieces | Maximum 32 pcs |
| Communicate range | Maximum 1200 m |

● Alarms

| | | |
|----------------------------|--|----------------------------|
| Alarm 1 Relay | SPDT type (a point 8A, b point 3A 220V) | SPST type 1a point 8A 220V |
| Alarm 2 Relay | SPST type 8A 220V | |
| Alarm setting range | -1999~9999 (Dot positions are different depended on the various Input Types) | |

2.2 Outer Dimension

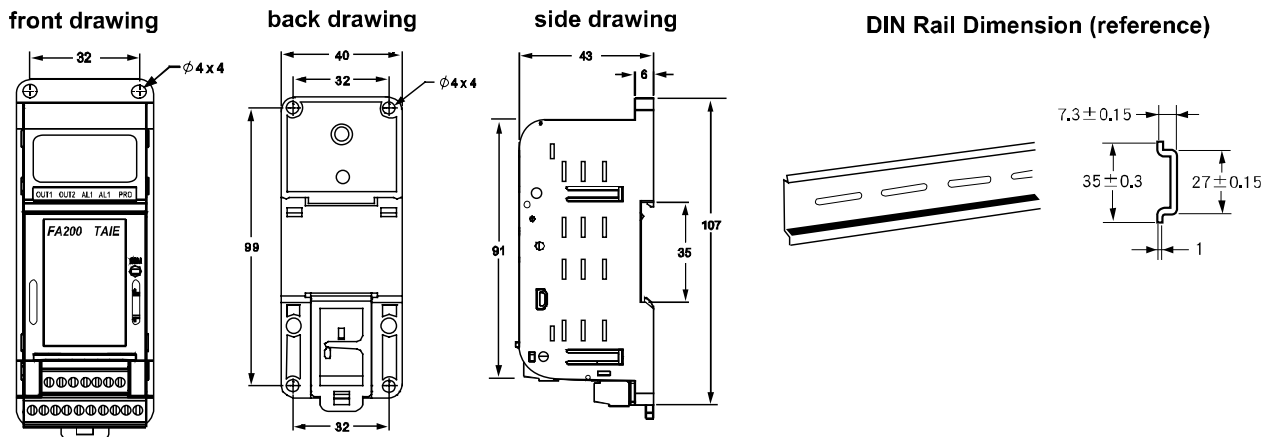

2.3 Terminal Wiring Diagram

FA 200 Advance Type Plug-in-out Pitch 3.5 mm

plug-in-out terminal M2.0 using "—" screwdriver

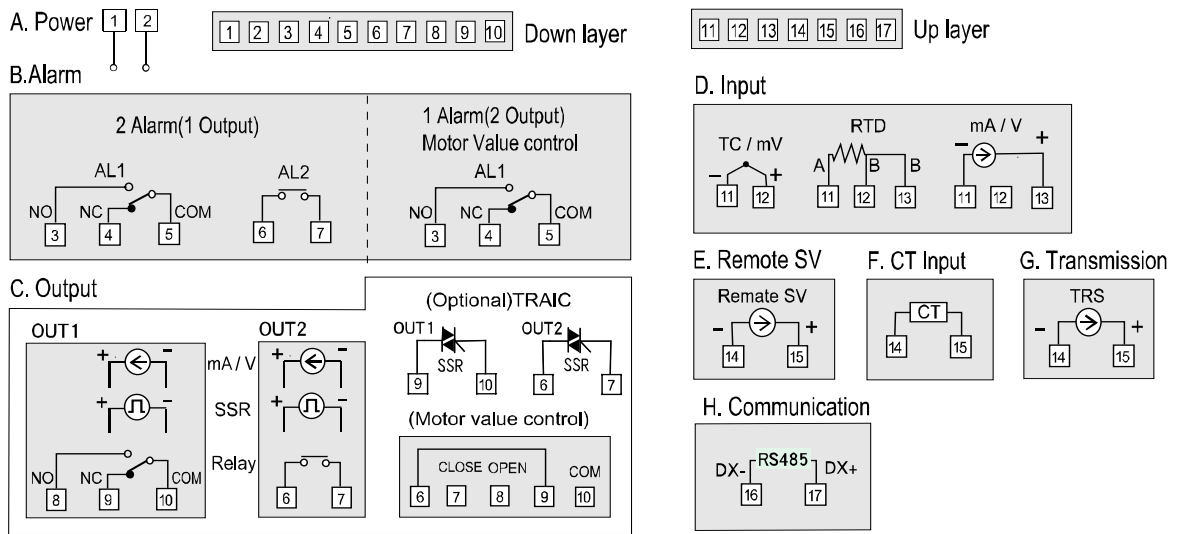

FA 211 Economic Type Fixed Pitch 5.0 mm

fixed terminal M2.6 using "+" screwdriver

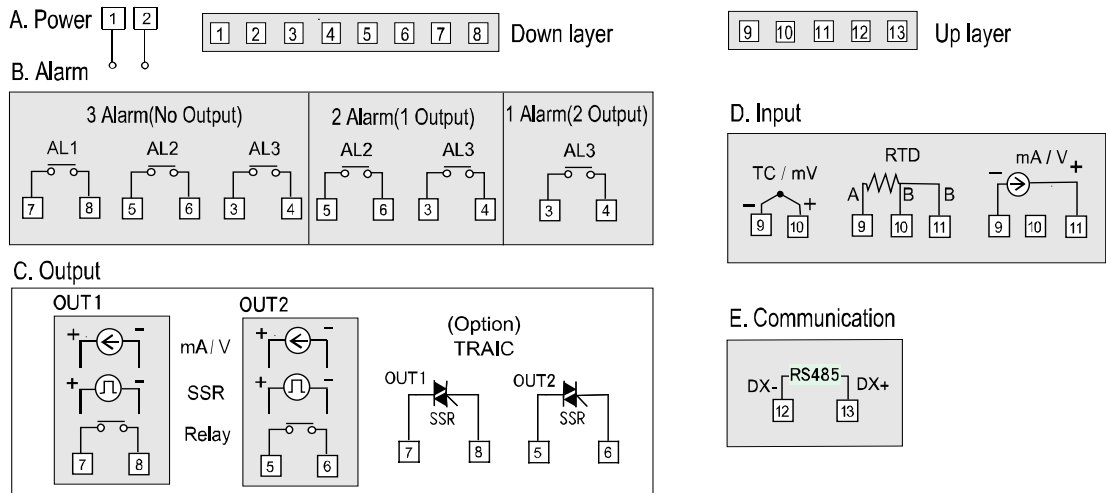

2.4 Assembly & Wiring

For FA200, please use plug-in-out wiring terminal => using width 2.4mm “—” screwdriver

For FA211, please fixed wiring terminal => using width 3.0mm “+” screwdriver

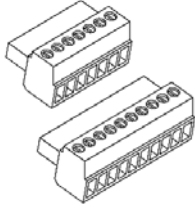
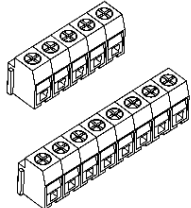
| plug-in-out terminal M2.0 using “—”screwdriver | fix terminal M2.6 using “+”screwdriver |
|---|---|
|  |  |

Selecting suitable electric wire of AWG 16 ~ AWG22 Lock Screw torque: 0.3 N.m (3 kgf.cm)

1. Please prevent the controllers from the environment of high noise, corrosive gas and high temperature and high humidity when controllers are assembling. (Normal operating environment : 0 ~ 50°C , 20 ~ 90%RH)
2. Power wiring must be distant from main power and load power to avoid the interference of noise.
3. To extend the wires of thermocouple input, please use the correspondent compensation leading wires.
4. To extend the wires of RTD input, please use shield wires which have the same materials among 3 wires with low resistance.
5. Please vertically install FA series by crabwise direction, hear the light voice of “Ka” to sure fixing and no loose when assembling FA series with on DIN rail.

Do not insert a small interval stick in the down half both of controllers to prevent the efficiency of compensating normal temperature.

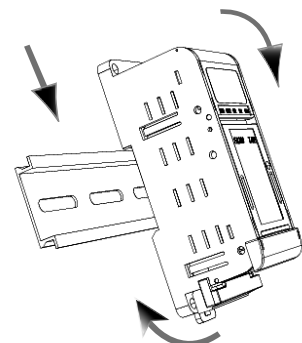

Please use attached a small interval stick in the up half both of controllers to assure the heat issuing good when many controllers set up together.

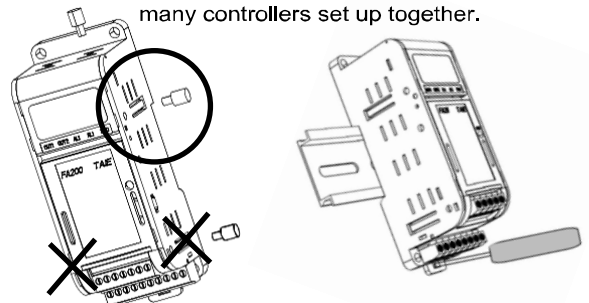

6. Separated secure cover of terminals are divided to up and down of two covers, please avoid the mistake and assure fixing when assembling

3 FY / FU Series

- Standard spec.

| Model | FY400 / FU48 | FY600 | FY700 / FU72 | FY800 / FU86 | FY900 / FU96 | FY100 | FY101 |
|-----------------------|---|--|--------------------|------------------|--------------------|---------------|---------------|
| Dimension | 48X48mm | 96X48mm | 72X72mm | 48X96mm | 96X96mm | 175X110mm | 90X90mm |
| Supply voltage | AC 85~265V , DC 15~50V (Option) | | | | | AC 85~265V | |
| Frequency | 50 / 60 HZ | | | | | | |
| Power consumption | approx 3VA | approx 4VA | approx 3VA | approx 4VA | approx 4VA | approx 4VA | approx 3VA |
| Input | Accuracy | 0.2 % FS \pm 1digit | | | | | |
| | Sample time | 250ms | | | | | |
| | TC | K , J , R , S , B , E , N , T , W5Re/W26Re , PLII , U , L | | | | | |
| | RTD | PT100,JPT100,JPT50 | | | | | |
| | mA dc | 4~20mA ,0~20mA | | | | | |
| | mV / V dc | 0~1V,0~5V,0~10V,1~5V,2~10V -10~10mV,0~10mV,0~20mV,0~50mV,10~50mV | | | | | |
| | Decimal point position | 0000 , 000.0 , 00.00 , 0.000 Available for linear input (mA / mV / V) | | | | | |
| Output 1 | Relay | SPST type | SPDT type | SPST type | SPDT type | SPDT type | SPDT type |
| | | 3A , 220V , electrical life:100,000 times or more (under rated load) | | | | | |
| | Voltage pulse | For SSR drive. ON : 24V , OFF : 0V , max load current : 20mA | | | | | |
| | mA dc | 4~20mA, 0~20mA. Maximum load resistance:560 Ω | | | | | |
| | Voltage dc | 0~5V , 0~10V , 1~5V , 2~10V . Max load current:20mA | | | | | |
| Alarm 1 | 3A , 220V , electrical life:100,000 times or more (under rated load) | | | | | | |
| Control algorithm | PID , PI , PD , P , ON / OFF(P=0) , FUZZY . | | | | | | |
| PID range | P: 0.0 ~ 200.0 % , I: 0~3600s , D: 0~900s | | | | | | |
| Isolation | Output terminals(control output , alarm , transmission) and input terminals are isolated separately | | | | | | |
| Isolated resistance | 10M Ω or more between input and case (ground) at DC 500 V 10M Ω or more between output and case (ground) at DC 500 V | | | | | | |
| Dielectric strength | 1000V AC for 1 minute between input terminal and case (ground) 1500V AC for 1 minute between output terminal and case (ground) | | | | | | |
| Operating temperature | 0~50 $^{\circ}$ C | | | | | | |
| Humidity range | 20~90%RH | | | | | | |
| Weight | 150g | 225g | 225g | 225g | 300g | 130g | 80g |
| Display Height | PV:7mm SV:7mm | PV:7mm SV:7mm | PV:14mm SV:10mm | PV:7mm SV:7mm | PV:14mm SV:10mm | _____ | _____ |

- **Optional Spec.**

| Model | FY400 / FU48 | FY600 | FY700 / FU72 | FY800 / FU86 | FY900 / FU96 | FY100 | FY101 |
|--|---|-----------|-----------------|-----------------|-----------------|-----------|---------------|
| Output 2 | For heating and cooling control use. Relay , SSR , 4~20mA , 0~20mA , 0~5V , 0~10V , 1~5V , 2~10V | | | | | | |
| Alarm 2 | Available | Available | Available | Available | Available | Available | Not available |
| | SPST type | SPDT type | SPST type | SPDT type | SPDT type | SPDT type | available |
| 3A , 220V , electrical life:100,000 times or more (under rated load) | | | | | | | |
| Alarm 3 | Not available | Available | Available | Available | Available | Available | Not available |
| | | SPST type | SPST type | SPST type | SPST type | SPST type | available |
| 3A , 220V , electrical life:100,000 times or more (under rated load) | | | | | | | |
| Heater Break Alarm (HBA) | Display range of heater current : 0.0~99.9A , Accuracy : 1%FS | | | | | | |
| | Included CT : SC-80-T (5.8mm dia , 0.0~80.0A) or SC-100-T (12mm dia , 0.0~99.9A) | | | | | | |
| | Alarm relay : AL1 | | | | | | |
| Transmission | Available for PV or SV transmission | | | | | | |
| | 4~20mA , 0~20mA , 0~1V , 0~5V , 0~10V , 1~5V , 2~10V | | | | | | |
| Remote SV | 4~20mA , 0~20mA , 0~1V , 0~5V , 0~10V , 1~5V , 2~10V | | | | | | |
| Communication | Protocol : MODBUS RTU , MODBUS ASCII , TAIE | | | | | | |
| | RS232 , RS485 , TTL | | | | | | |
| | Baud rate: 2400 , 4800 , 9600 , 19200 , 38400 bps. | | | | | | |
| | Data bits : 8 , Stop bit : 1 or 2bit , Odd or Even parity. | | | | | | |
| Water/Dust proof | IP65 | | | | | | |

- **Special control output (OUT1)**

| Model | FY400 / FU48 | FY600 | FY700 / FU72 | FY800 / FU86 | FY900 / FU96 | FY100 | FY101 |
|--|-----------------|---------------|-----------------|-----------------|-----------------|---------------|---------------|
| 1φ zero crossing control(1φSSR) | Available | Not available | Available | Not available | Available | Not available | Not available |
| 3φ zero crossing control(3φSSR) | Not available | | | | Available | Not available | Not available |
| Motor valve control | Available | | | | | | |
| 1φ phase angle control(1φSCR) | Not available | Available | | | | Available | Not available |
| 3φ phase angle control(3φSCR) | Not available | | | | Available | Not available | Not available |

- **Programmable RAMP/SOAK**

| Model | PFY400 | PFY600 | PFY700 | PFY800 | PFY900 | PFY100 | PFY101 |
|-------------------------------|--|---------------|---------------|---------------|---------------|---------------|---------------|
| Programmable RAMP/SOAK | 2 patterns with 8 segment each. The 2 patterns can be linked together as 16 segments use. | | | | | | |

4. Terminal arrangement

4.1 FY400 / FU48 Terminals (48mm x 48mm , DIN 1/16)

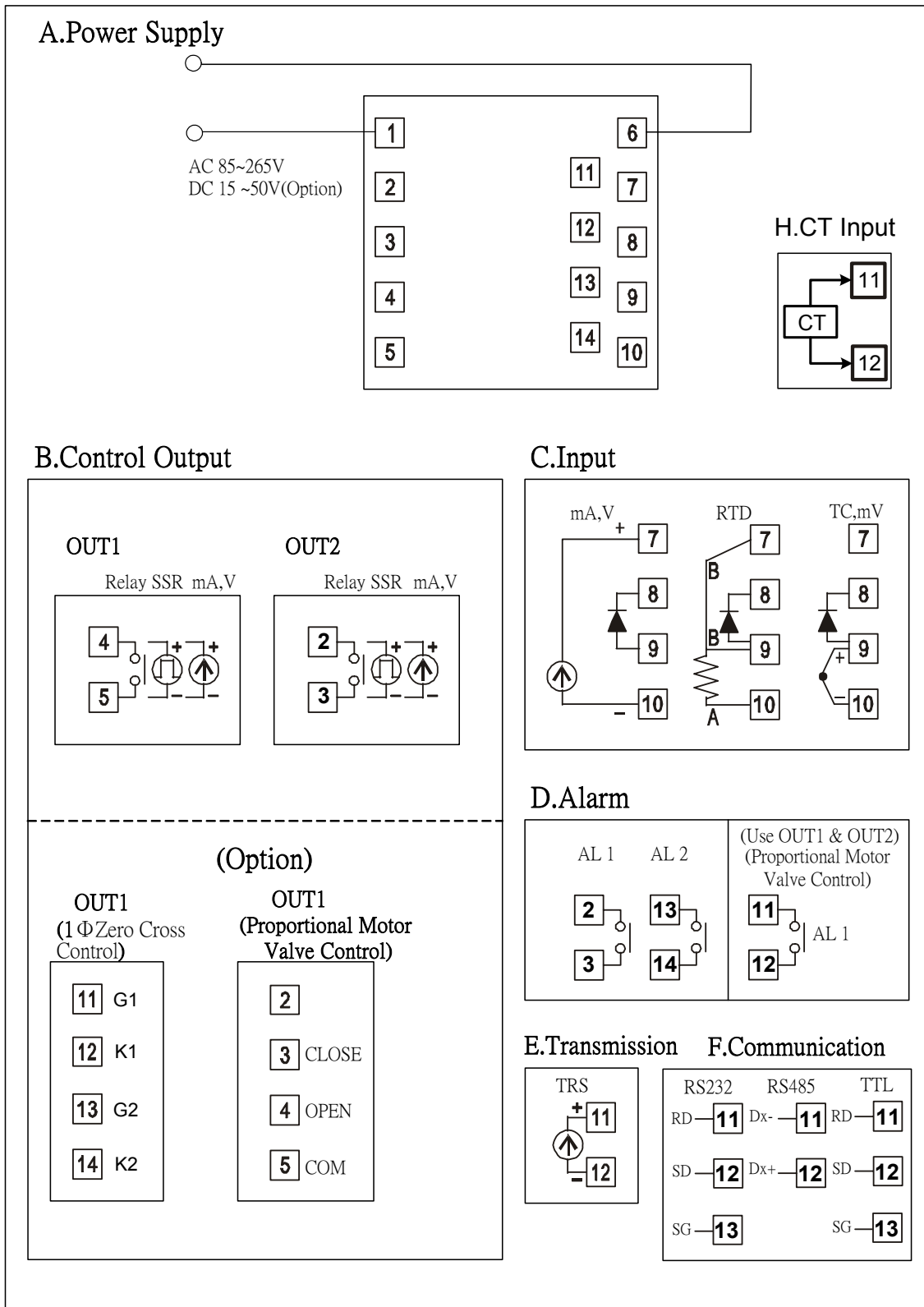

4.2 FY600 Terminals (96mm x 48mm , DIN 1/8)

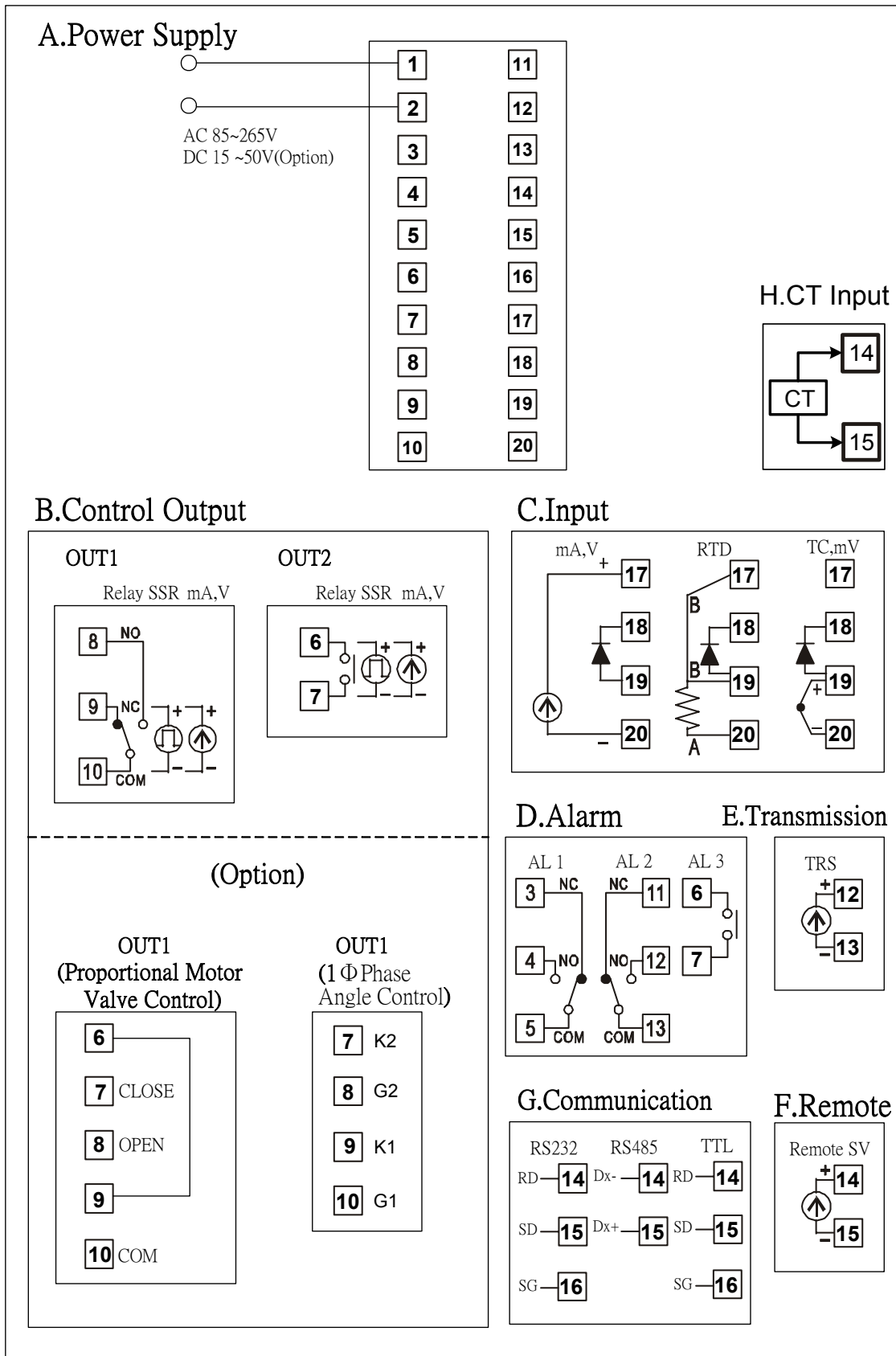

4.3 FY700 / FU72 Terminals (72mm x 72mm)

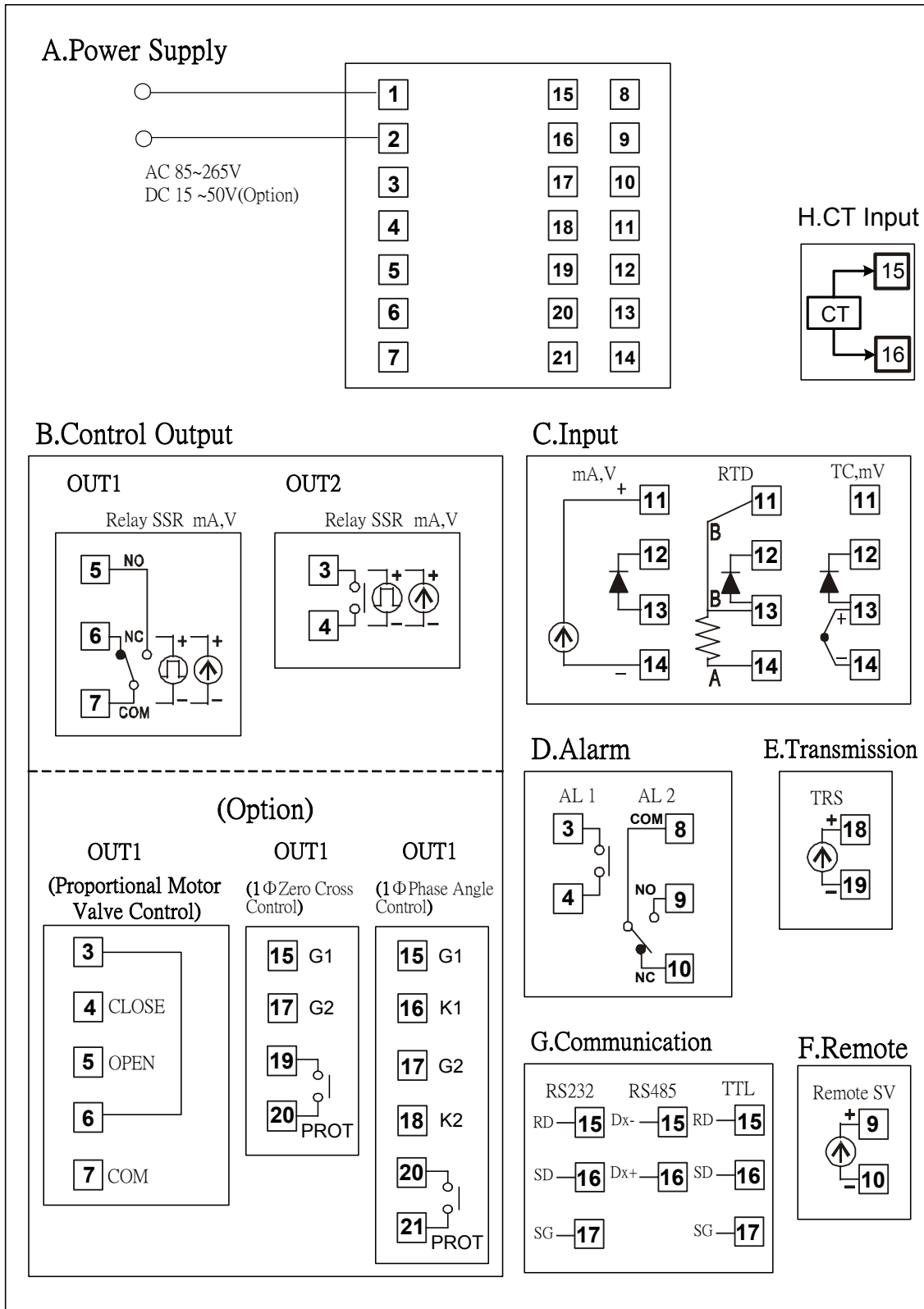

4.4 FY800 / FU86 Terminals (48mm x 96mm , DIN 1/8)

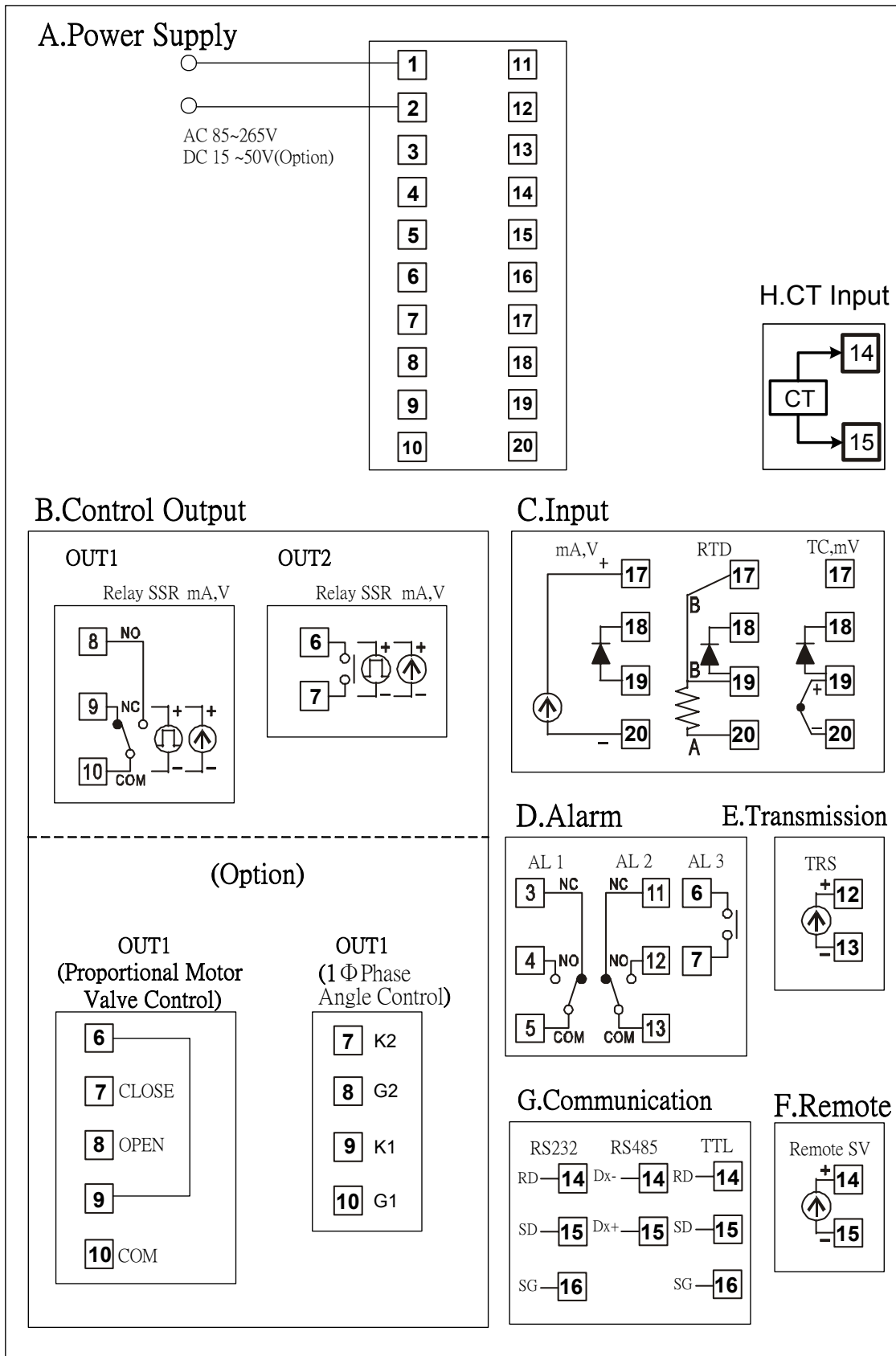

4.5 FY900 / FU96 Terminals (96mm x 96mm , DIN 1/4)

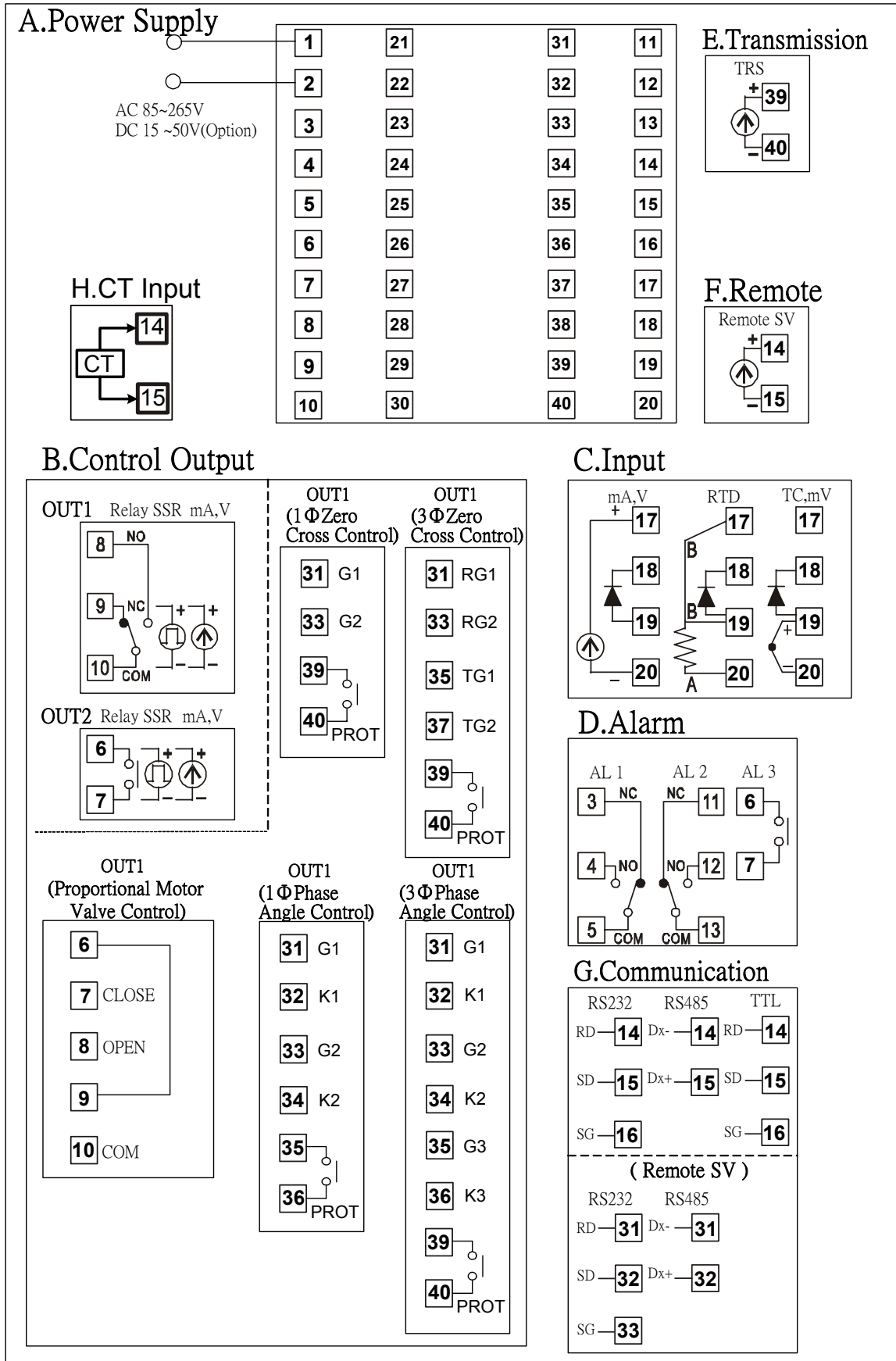

4.6 FY100 Terminals (175mm x 110mm)

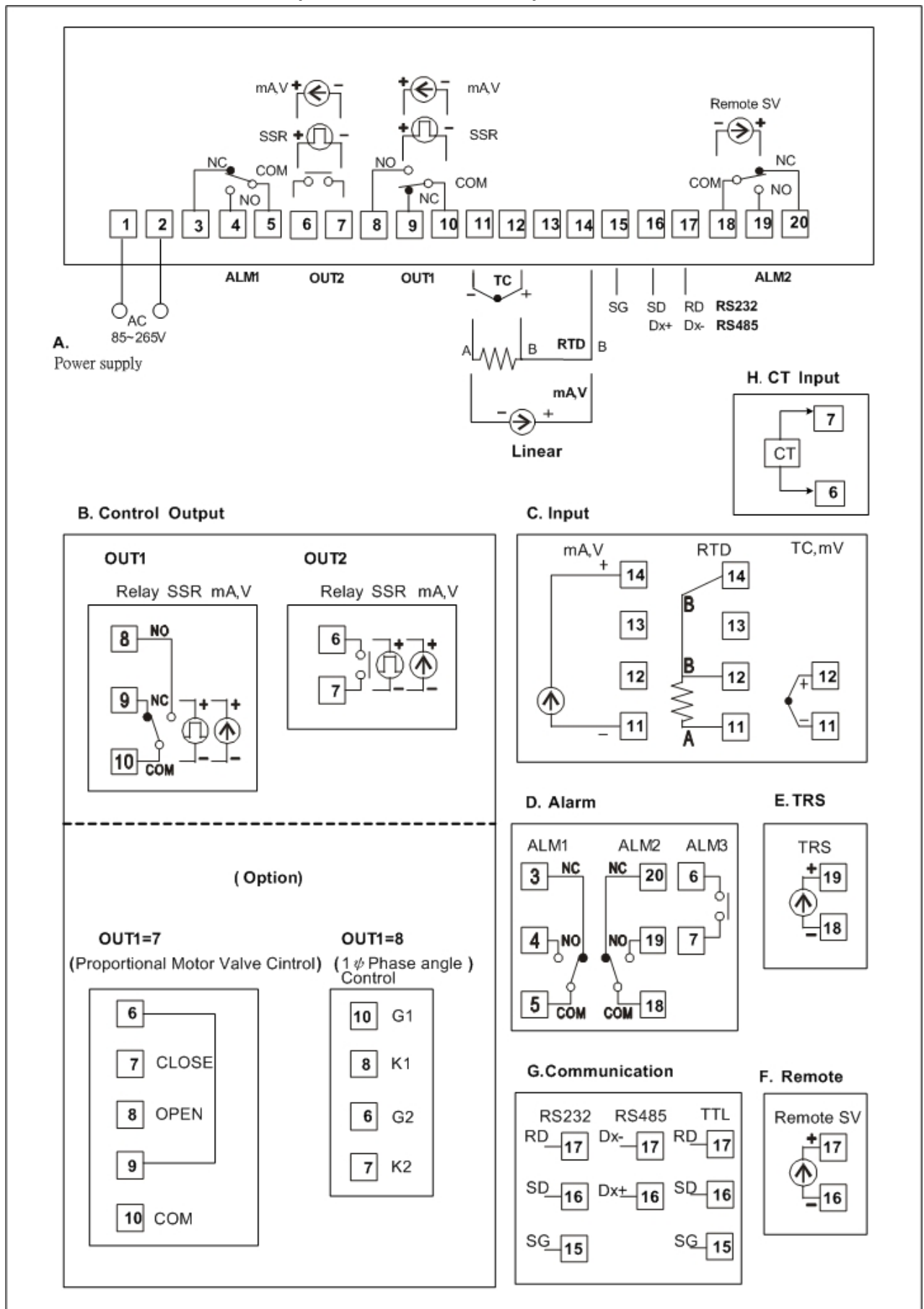

4.7 FY101 Terminals (90mm x 90mm)

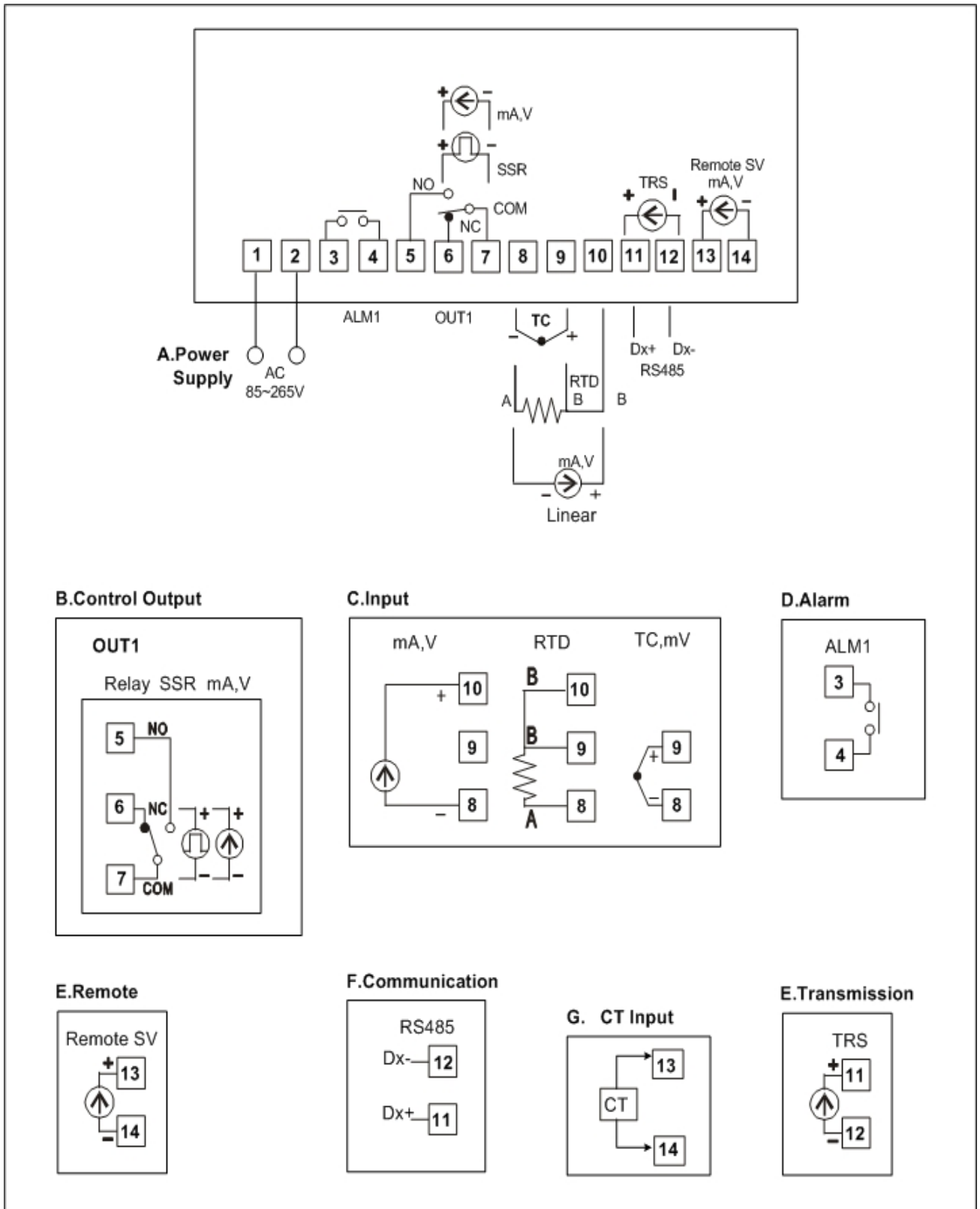

B. Control Output

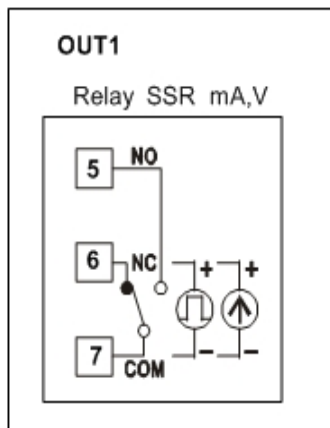

C. Input

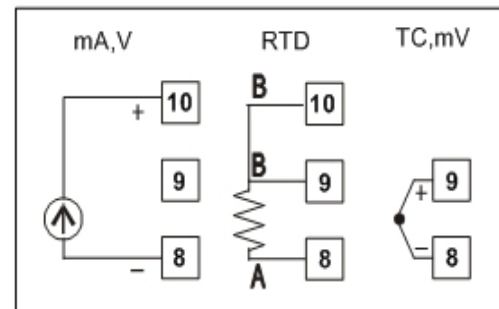

D. Alarm

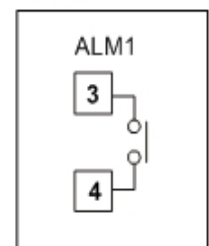

E. Remote

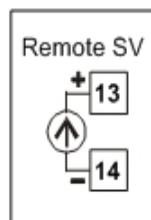

F. Communication

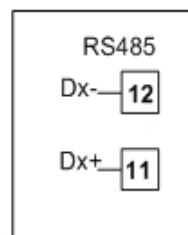

G. CT Input

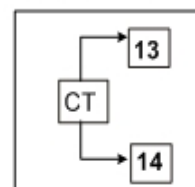

E. Transmission

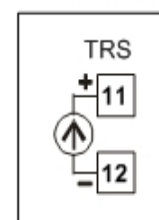

5. External dimension and panel cutout < Unit : mm >

5.1 FY100

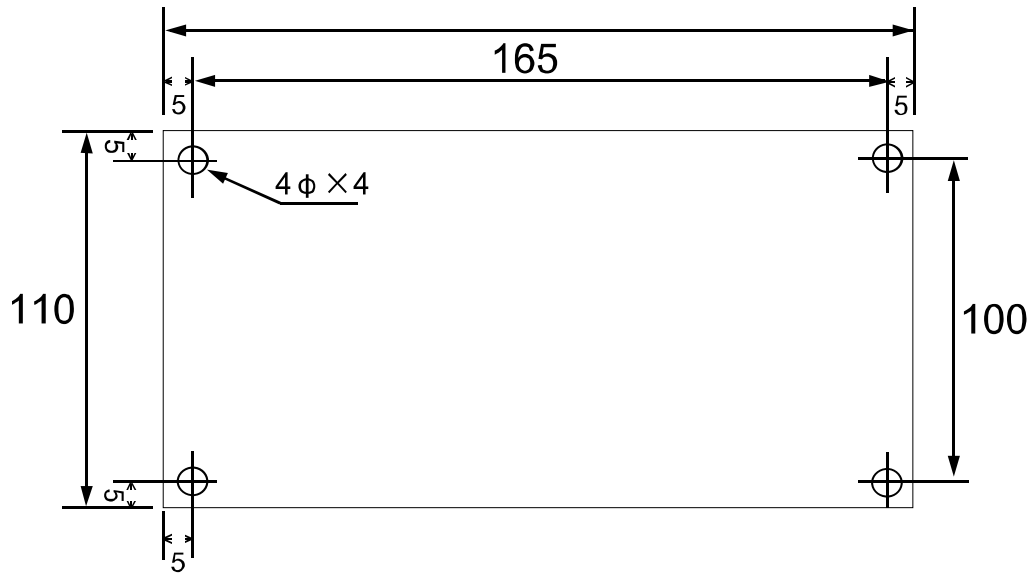

5.2 FY101

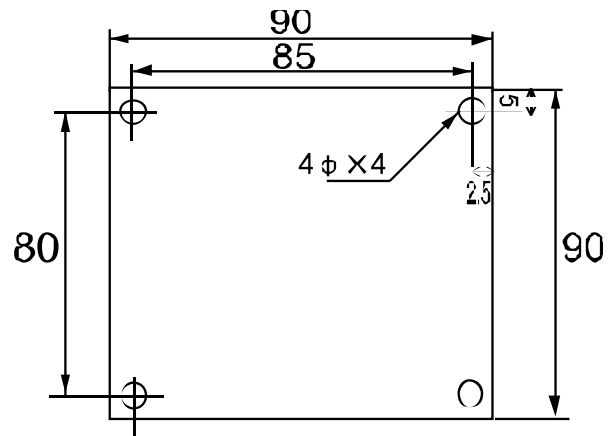

5.3 FY400~900 & FU48~96

**FY400/
FU48**

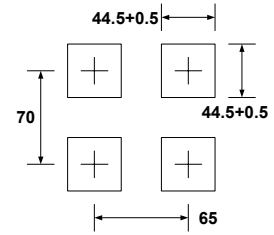
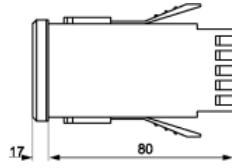
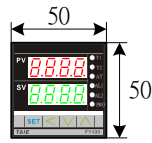

FY600

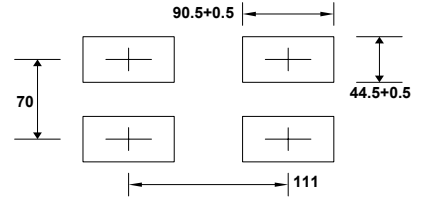
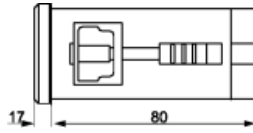
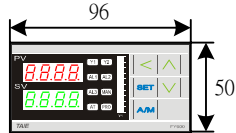

**FY700/
FU72**

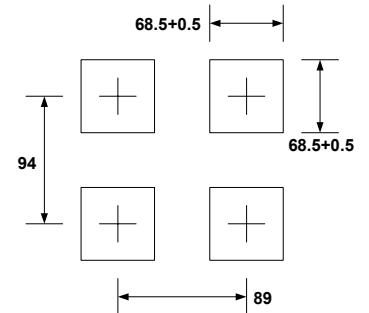
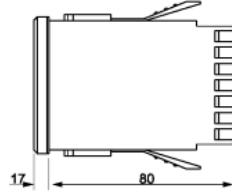
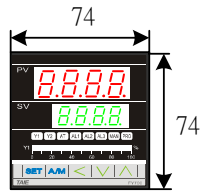

**FY800/
FU86**

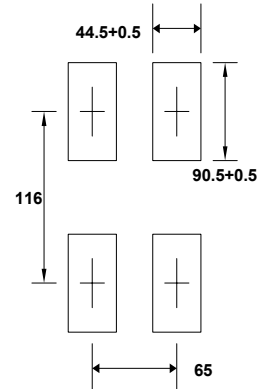
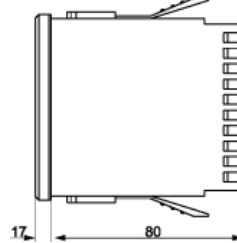
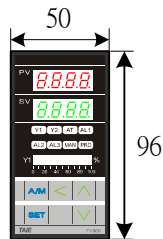

**FY900/
FU96**

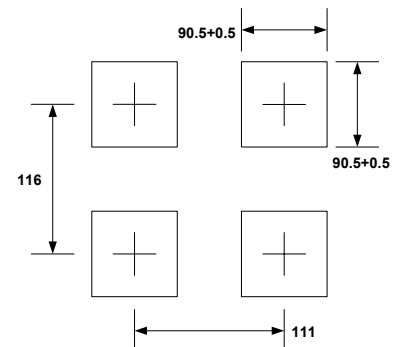
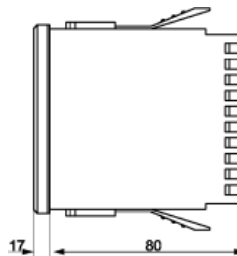
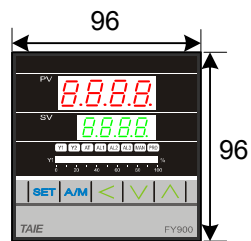

6. Parts description

FY400/FU48

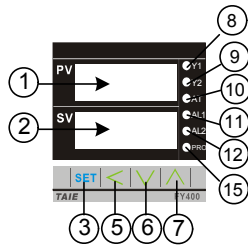

FY600

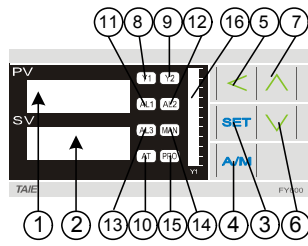

FY800/FU86

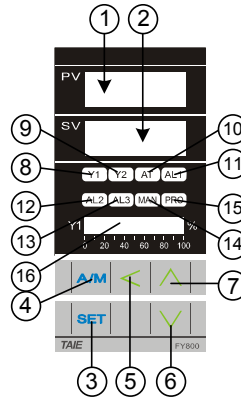

FY700/FY900/FU72/FU96
FY100/101 External
Interface Unit

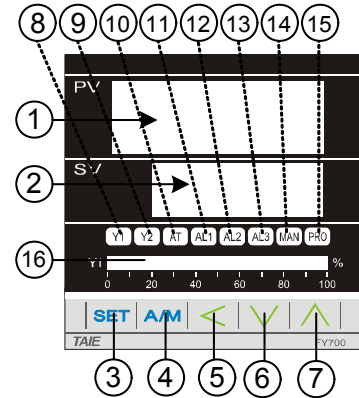

| SYMBOL | NAME | | FUNCTION |
|--------|------|----------------------------------|---|
| PV | ① | Measured value (PV) display | Displays PV or various parameter symbols (Red) |
| SV | ② | Set value (SV) display | Displays SV or various parameter set values (Green) |
| SET | ③ | Set key | Used for parameter calling up and set value registration |
| A/M | ④ | Auto/Manual key | Switches between Auto(PID) output mode and Manual output mode. |
| < | ⑤ | Shift key | Shift digits when settings are changed |
| ∨ | ⑥ | Down key <i>*Program hold</i> | Decrease numbers (-1000,-100,-10,-1) <i>* Program hold <Programmable controller></i> |
| ∧ | ⑦ | Up key <i>*Program run</i> | Decrease numbers (+1000,+100,+10,+1) <i>* Program run <Programmable controller></i> |
| OUT1 | ⑧ | OUT1 lamp | Lights when OUT1 is activated (Green) |
| OUT2 | ⑨ | OUT2 lamp | Lights when OUT2 is activated (Green) ◦ |
| AT | ⑩ | Auto tuning lamp | Lights when Auto tuning is activated (Orange) |
| AL1 | ⑪ | Alarm 1 lamp | Lights when Alarm 1 is activated (Red) |
| AL2 | ⑫ | Alarm 2 lamp | Lights when Alarm 2 is activated (Red) |
| AL3 | ⑬ | Alarm 3 lamp | Lights when Alarm 3 is activated (Red) |
| MAN | ⑭ | Manual output lamp | Lights when manual output is activated (Orange) |
| PRO | ⑮ | <i>*Program running lamp</i> | <i>*Flashes when program is running <Programmable controller> ◦</i> |
| OUT1% | ⑯ | OUT% bar-graph display | Output% is displayed on 10-dot LED. |

7. Operations

7.1 Power On

Controller will display as below

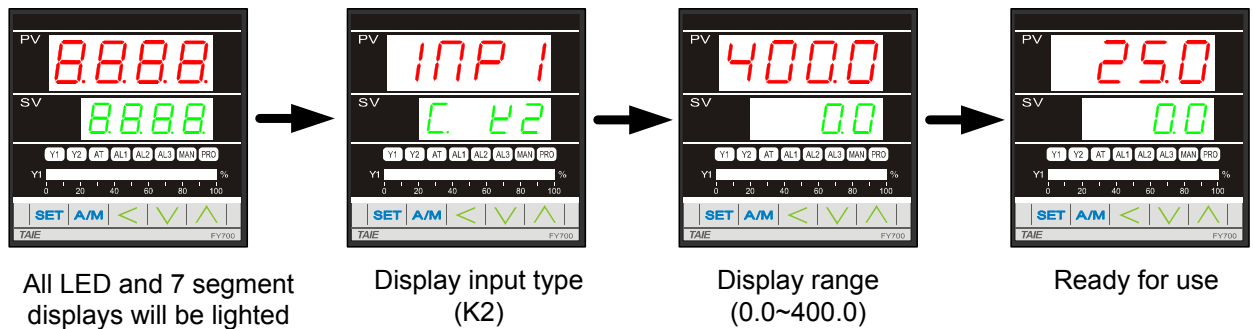

7.2 Change the Set Value (SV)

Change SV from 0.0 to 100.0

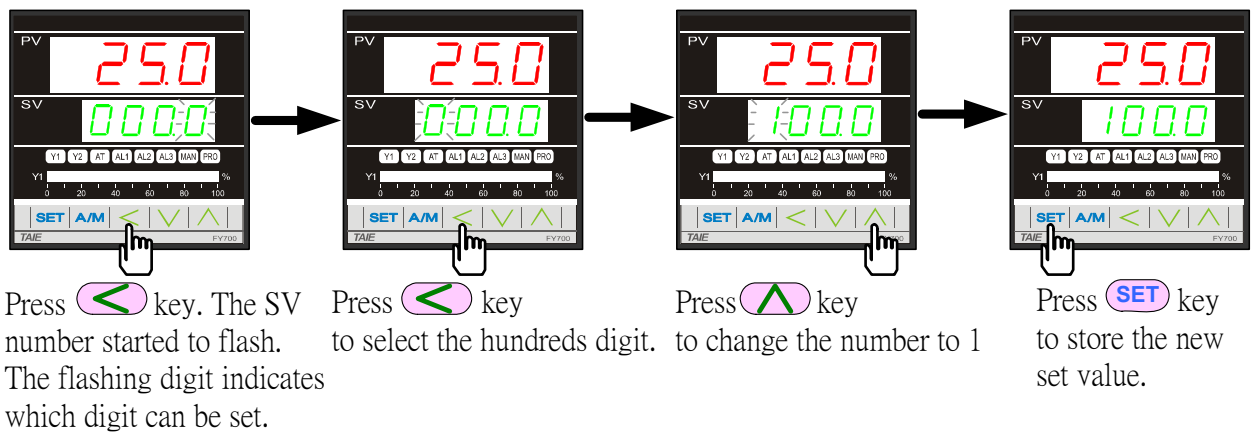

7.3 Change the Alarm Value

Change AL1 value to "5.0" (AL1 active, if PV exceeds SV over 5.0)

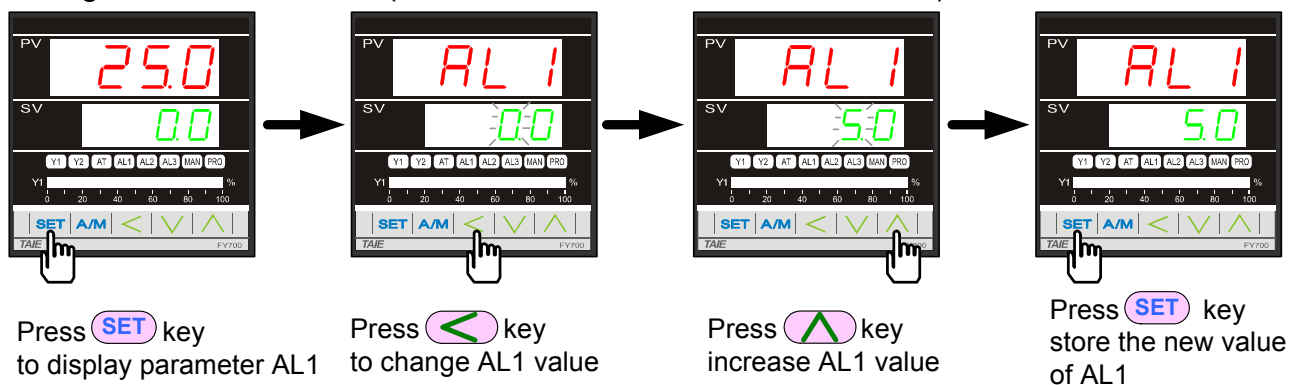

* There are total 16 alarm mode types, please refer to "alarm mode" in page 30

* To change alarm mode, press + key 3 seconds to enter Level 3 (Input Level) and then change ALD1/ALD2/ALD3 value.

7.4 Autotuning (AT)

Use AT function to automatically calculate and set the optimize PID value for your system.

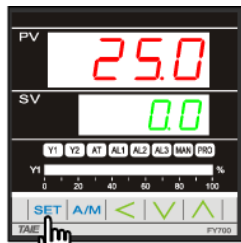

Press **SET** key to display parameter AT.

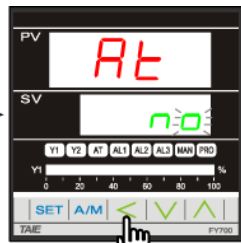

Press **←** key to change AT setting

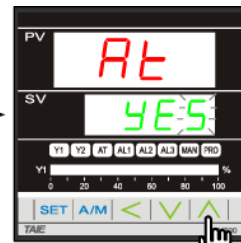

Press **→** key change AT to "YES"

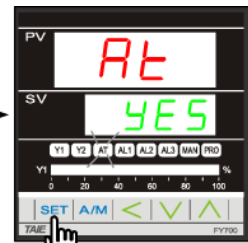

Press **SET** key Start auto tuning (AT lamp will be lighted on)

Autotuning
ATVL=0

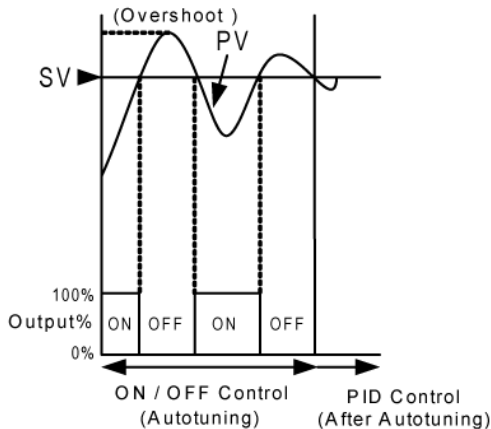

Autotuning

ATVL=20

*Set ATVL to prevent overshoot occurred during autotuning process.

To set ATVL, press **SET** key 3 seconds to enter Level 2 (PID Level) and then change the value.

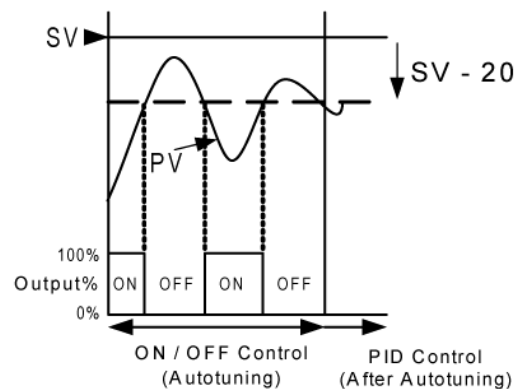

Autotuning failure

- Possible cause 1: ATVL is too big. (If not sure, set ATVL=0)
- Possible cause 2: Calculation time is too long. (Set PID parameter manually)

7.5 Programmable RAMP / SOAK (Only available for PFY model)

*For detail of the programmable instruction, please refer with page 25.

Assume the temperature profile is as below (use total 4 segments)

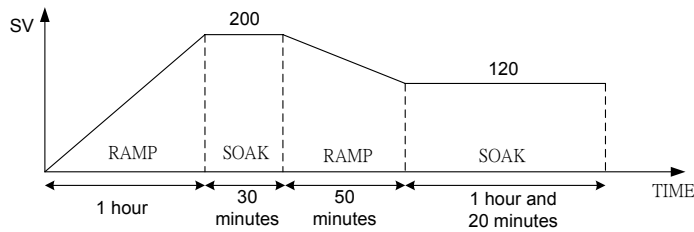

Please operate controller as following steps:

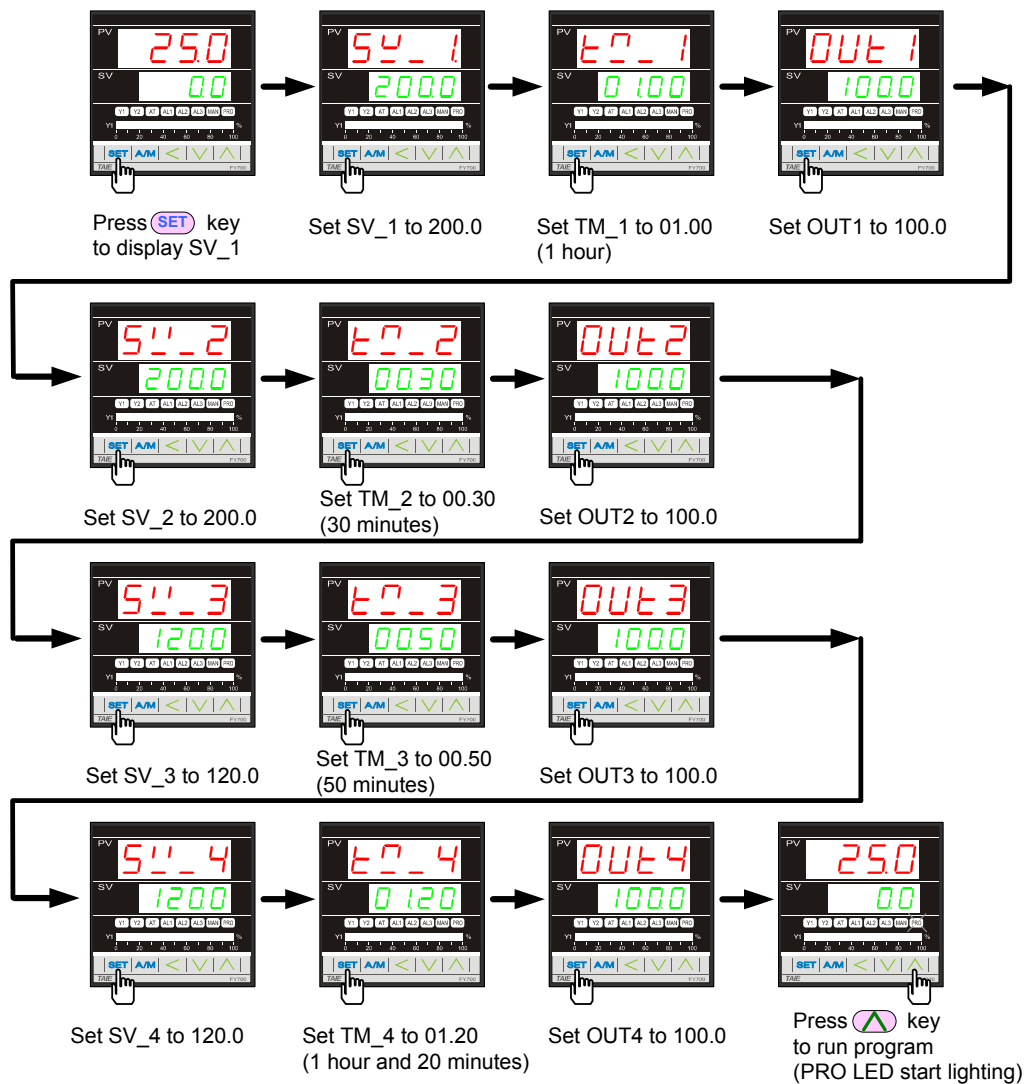

8. Operation levels

8.1 Levels diagram

1. When the power is on, it will stay at Level 1 (User Level) automatically.
2. The controller returns to Level 1 if there is no key operation within 60 seconds.
3. In any Level, press **(A/M)** key twice will return to Level 1.
(FU48 don't have **(A/M)** key)

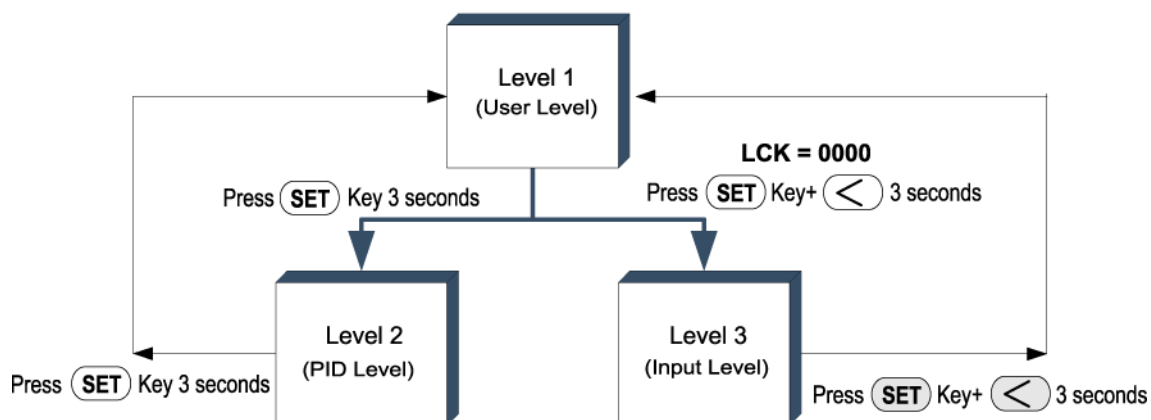

8.2 Lock function

To use lock function, please set parameter “LCK” in level 2.

| LCK | Levels entering available | | | | Parameters which can be changed |
|------|---------------------------|---------------|-----------------|---------------|------------------------------------|
| | Level 1 (User) | Level 2 (PID) | Level 3 (Input) | Level 4 (SET) | |
| 0000 | ⊙ | ⊙ | ⊙ | ----- | All parameters (Factory set value) |
| 1111 | ⊙ | ⊙ | ----- | ⊙ | All parameters |
| 0100 | ⊙ | ⊙ | ----- | ----- | All parameters except level 3 |
| 0110 | ⊙ | ⊙ | ----- | ----- | Parameters in level 1 |
| 0001 | ⊙ | ⊙ | ----- | ----- | “SV” and “LCK” |
| 0101 | ⊙ | ⊙ | ----- | ----- | Only “LCK” |

9. Parameters

9.1 Level 1 (User Level)

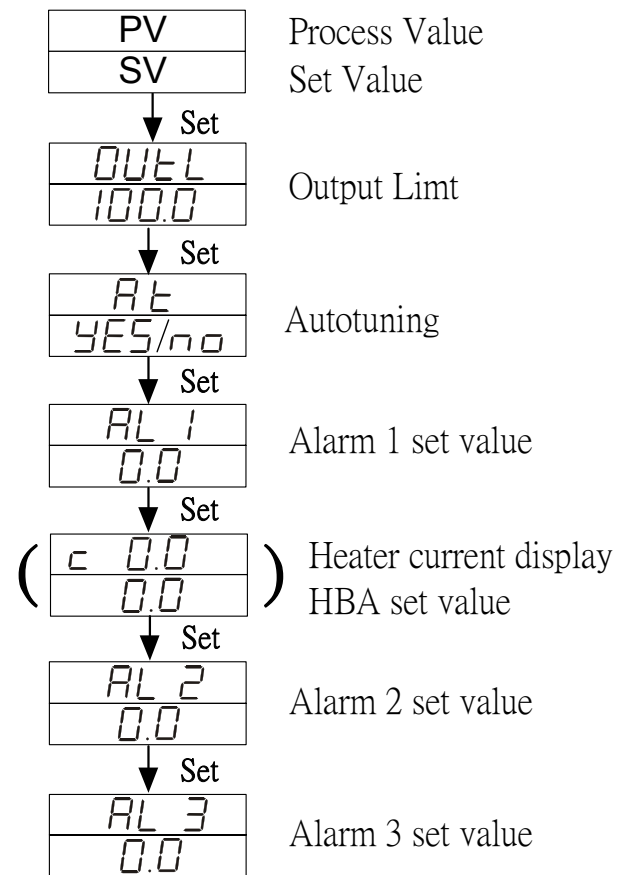

9.2 LEVEL 2 (PID Level)

To enter level 2, press SET key 3 seconds in level 1

9.2.1 Level 2 parameters display /hiding condition

- | | |
|---|---|
| 1. Press SET key 3 seconds to enter level 2. | 1. Press SET key 3 seconds to enter level 2. |
| 2. Set LCK to "1111". | 2. Set LCK to "1111". |
| 3. Press SET key and ◀ key 3 seconds, to enter level 4 (Set level). | 3. Press SET key and ◀ key 3 seconds, to enter level 4 (Set level). |
| 4. Set OUTY to "0" (Single output-P1) . | 4. Set OUTY to "1" (Dual output - P1/P2) . |

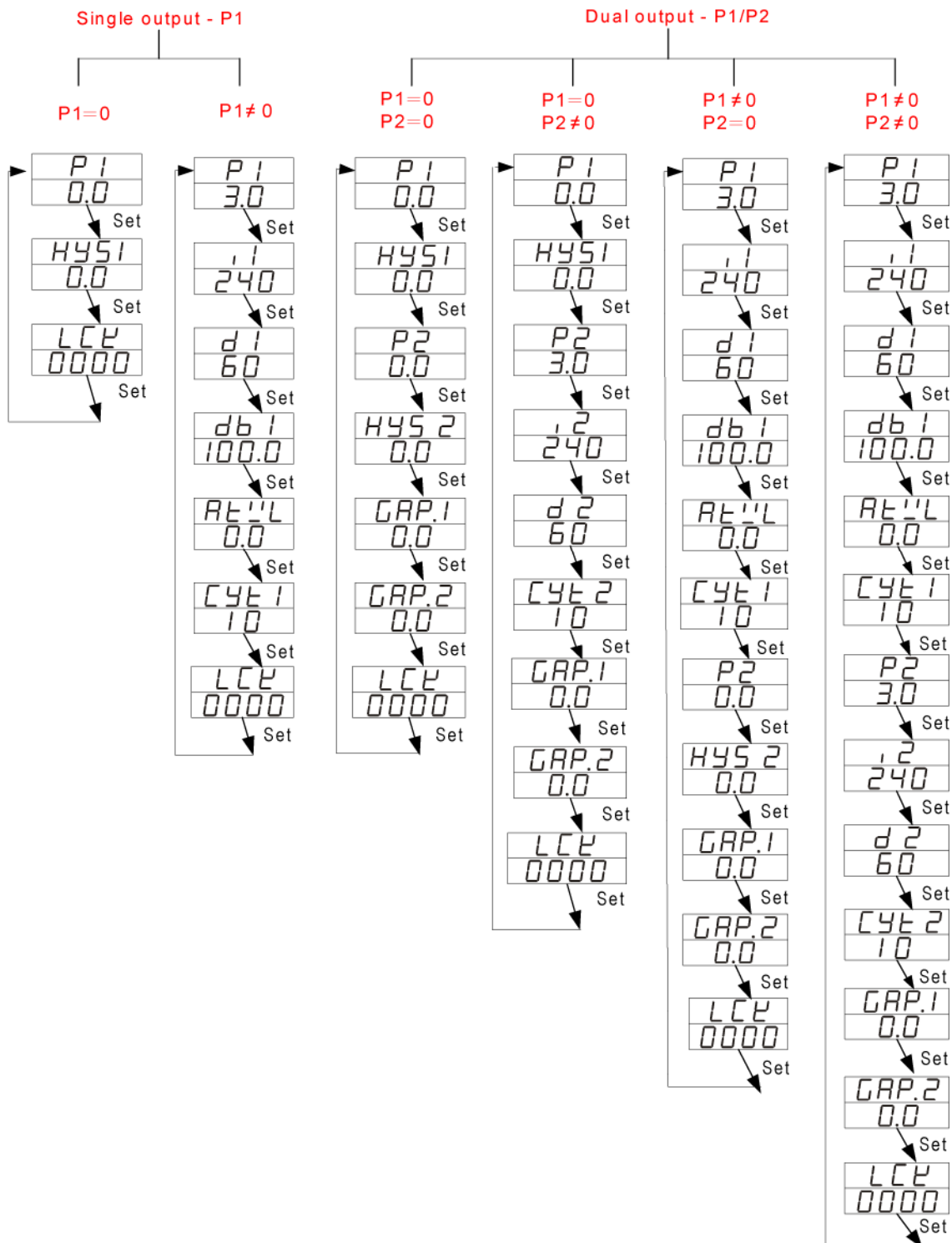

9.2.2 Description of parameters

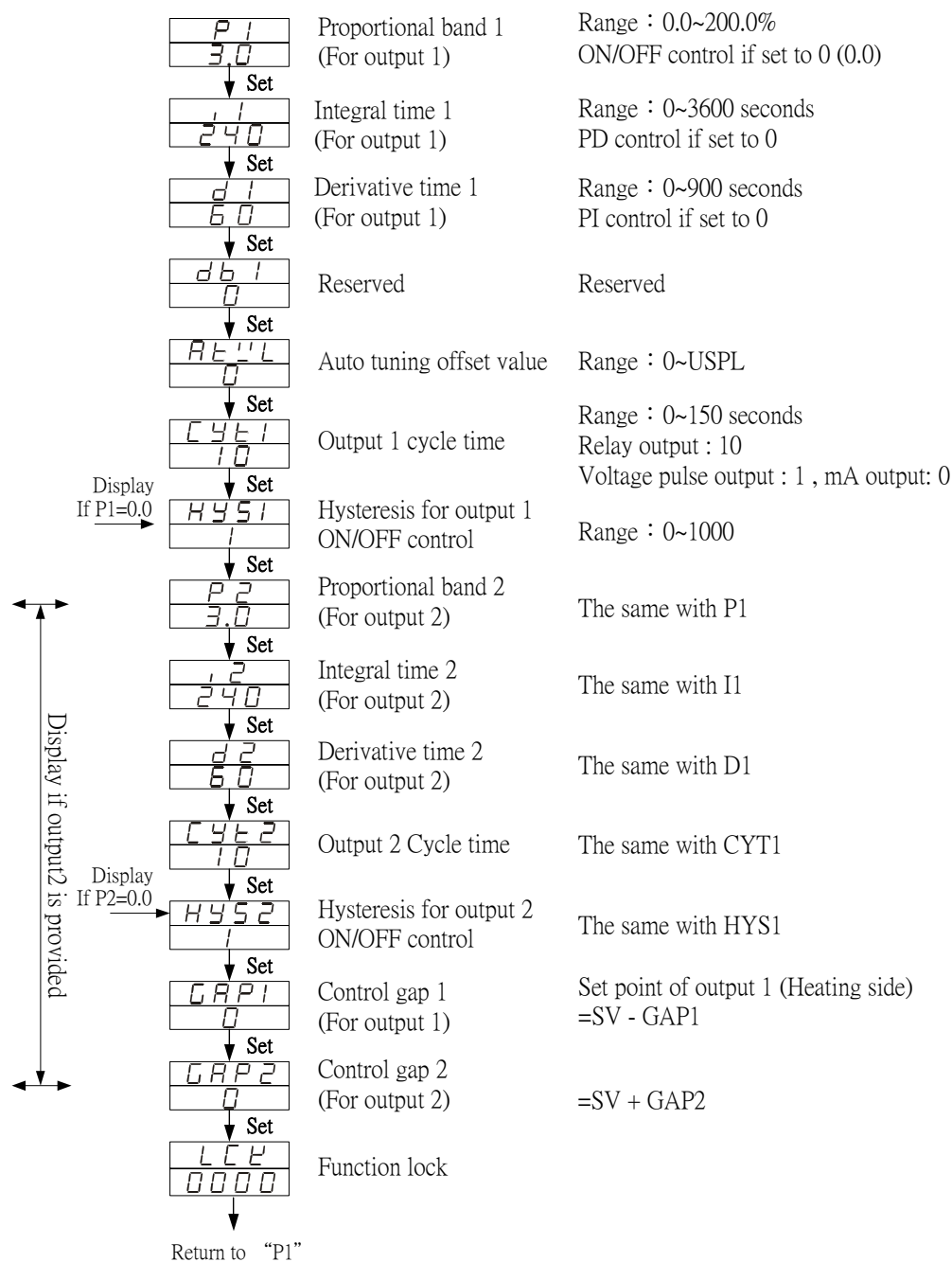

| LCK | Levels entering available | | | | Parameters which can be changed |
|------|---------------------------|---------------|-----------------|---------------|---------------------------------|
| | Level 1 (User) | Level 2 (PID) | Level 3 (Input) | Level 4 (SET) | |
| 0000 | ⊙ | ⊙ | ⊙ | ----- | All parameters (default value) |
| 1111 | ⊙ | ⊙ | ----- | ⊙ | All parameters |
| 0100 | ⊙ | ⊙ | ----- | ----- | All parameters except level 3 |
| 0110 | ⊙ | ⊙ | ----- | ----- | Parameters in level 1 |
| 0001 | ⊙ | ⊙ | ----- | ----- | "SV" and "LCK" |
| 0101 | ⊙ | ⊙ | ----- | ----- | Only "LCK" |

9.3 LEVEL 3 (Input Level)

To enter level 3 , set LCK to "0000" and then press SET key + Shift() key 3 seconds.

| | | |
|---|--|--|
| <div style="border: 1px solid black; padding: 2px; width: fit-content; margin: 0 auto;">INP1</div> <div style="border: 1px solid black; padding: 2px; width: fit-content; margin: 0 auto;">22</div> | Input type selection | |
| ↓ Set | | |
| <div style="border: 1px solid black; padding: 2px; width: fit-content; margin: 0 auto;">ANL1</div> <div style="border: 1px solid black; padding: 2px; width: fit-content; margin: 0 auto;">0</div> | Analog input low limit calibration (Used for mA and V input) | Range : -1999 ~ 9999 |
| ↓ Set | | |
| <div style="border: 1px solid black; padding: 2px; width: fit-content; margin: 0 auto;">ANH1</div> <div style="border: 1px solid black; padding: 2px; width: fit-content; margin: 0 auto;">5000</div> | Analog input high limit calibration (Used for mA and V input) | Range : 0 ~ 9999 |
| ↓ Set | | |
| <div style="border: 1px solid black; padding: 2px; width: fit-content; margin: 0 auto;">dP</div> <div style="border: 1px solid black; padding: 2px; width: fit-content; margin: 0 auto;">0000</div> | Decimal point position (Available for mA and V input) | 0000 , 000.0 , 00.00 , 0.000 |
| ↓ Set | | |
| <div style="border: 1px solid black; padding: 2px; width: fit-content; margin: 0 auto;">L.S.P.L</div> <div style="border: 1px solid black; padding: 2px; width: fit-content; margin: 0 auto;">0.0</div> | Lower Set-Point Limit | Scaling Low Limit |
| ↓ Set | | |
| <div style="border: 1px solid black; padding: 2px; width: fit-content; margin: 0 auto;">U.S.P.L</div> <div style="border: 1px solid black; padding: 2px; width: fit-content; margin: 0 auto;">400.0</div> | Upper Set-Point Limit | Scaling High Limit |
| ↓ Set | | |
| <div style="border: 1px solid black; padding: 2px; width: fit-content; margin: 0 auto;">ANL2</div> <div style="border: 1px solid black; padding: 2px; width: fit-content; margin: 0 auto;">0</div> | Remote input low limit calibration | Range : -1999 ~ 9999 |
| ↓ Set | | |
| <div style="border: 1px solid black; padding: 2px; width: fit-content; margin: 0 auto;">ANH2</div> <div style="border: 1px solid black; padding: 2px; width: fit-content; margin: 0 auto;">5000</div> | Remote input high limit calibration | Range : 0 ~ 9999 |
| ↓ Set | | |
| <div style="border: 1px solid black; padding: 2px; width: fit-content; margin: 0 auto;">ALd1</div> <div style="border: 1px solid black; padding: 2px; width: fit-content; margin: 0 auto;">11</div> | Alarm mode of AL1 | Range:00~19 Refer to "Alarm mode type" |
| ↓ Set | | |
| <div style="border: 1px solid black; padding: 2px; width: fit-content; margin: 0 auto;">ALt1</div> <div style="border: 1px solid black; padding: 2px; width: fit-content; margin: 0 auto;">99.59</div> | Alarm time of AL1 | Range : 0~99 Min 59 Secs 0=Flicker Alarm , 99:59=Continued Others=On delay time (If ALD=07 , ALT means alarm on time) |
| ↓ Set | | |
| <div style="border: 1px solid black; padding: 2px; width: fit-content; margin: 0 auto;">ALd2</div> <div style="border: 1px solid black; padding: 2px; width: fit-content; margin: 0 auto;">0</div> | Alarm mode of AL2 | The same with ALD1 |
| ↓ Set | | |
| <div style="border: 1px solid black; padding: 2px; width: fit-content; margin: 0 auto;">ALt2</div> <div style="border: 1px solid black; padding: 2px; width: fit-content; margin: 0 auto;">99.59</div> | Alarm time of AL2 | The same with ALT1 |
| ↓ Set | | |
| <div style="border: 1px solid black; padding: 2px; width: fit-content; margin: 0 auto;">ALd3</div> <div style="border: 1px solid black; padding: 2px; width: fit-content; margin: 0 auto;">0</div> | Alarm mode of AL3 | The same with ALD1 |
| ↓ Set | | |
| <div style="border: 1px solid black; padding: 2px; width: fit-content; margin: 0 auto;">ALt3</div> <div style="border: 1px solid black; padding: 2px; width: fit-content; margin: 0 auto;">99.59</div> | Alarm time of AL3 | The same with ALT1 |
| ↓ Set | | |
| <div style="border: 1px solid black; padding: 2px; width: fit-content; margin: 0 auto;">HYSA</div> <div style="border: 1px solid black; padding: 2px; width: fit-content; margin: 0 auto;">0.0</div> | Hysteresis of all Alarm | Range : 0~1000 |
| ↓ Set | | |
| <div style="border: 1px solid black; padding: 2px; width: fit-content; margin: 0 auto;">CLD1</div> <div style="border: 1px solid black; padding: 2px; width: fit-content; margin: 0 auto;">230</div> | Output 1 low limit calibration (Used for mA and V output) | Range : 0 ~ 9999 |
| ↓ Set | | |
| <div style="border: 1px solid black; padding: 2px; width: fit-content; margin: 0 auto;">CHD1</div> <div style="border: 1px solid black; padding: 2px; width: fit-content; margin: 0 auto;">3600</div> | Output 1 high limit calibration (Used for mA and V output) | Range : 0 ~ 9999 |
| ↓ Set | | |

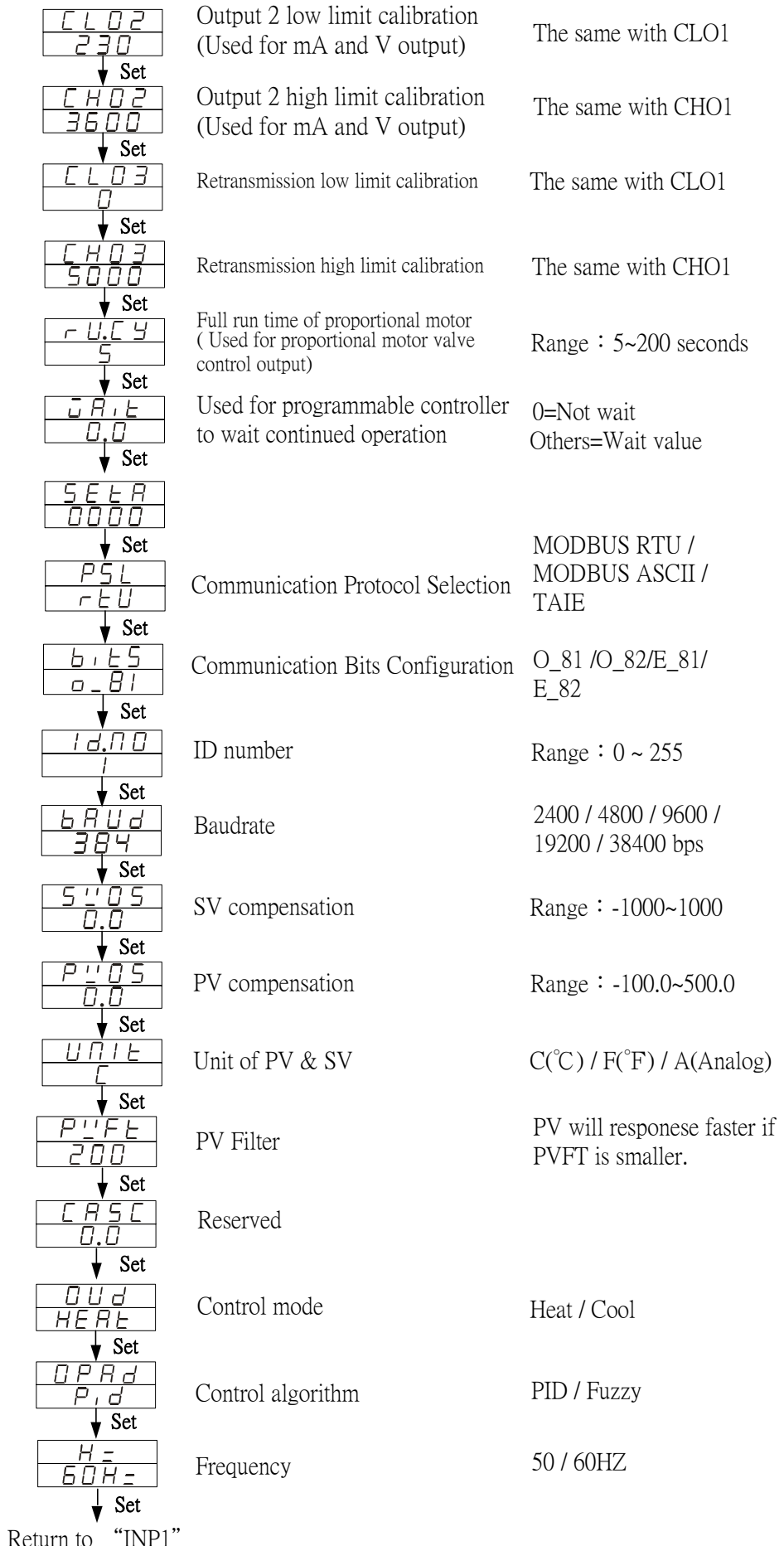

Return to "INP1"

9.4 Level 4 (SET level)

To enter level 4, set LCK to "1111" and then press SET key + Shift(◀) key 3 seconds.

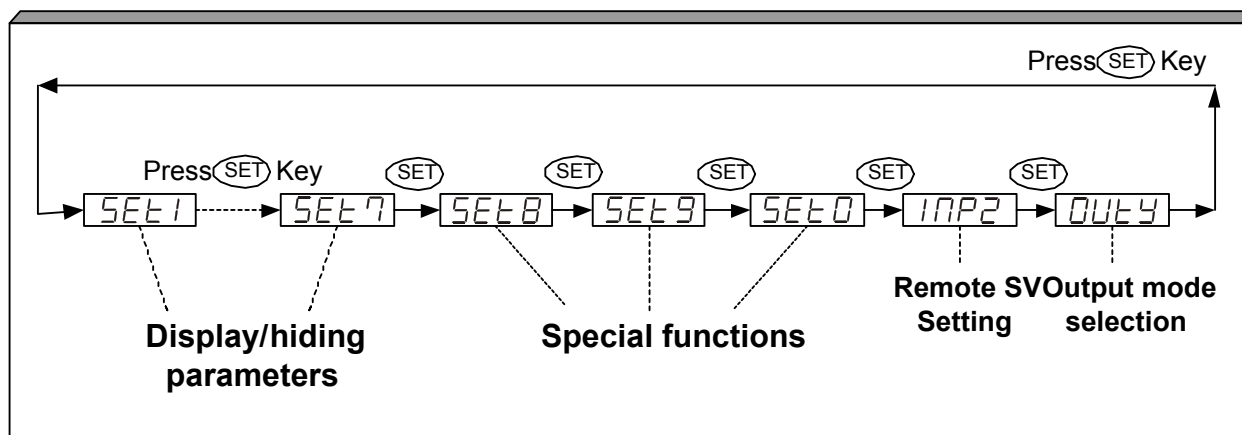

9.4.1 How to hide parameters (Use SET1~SET7)

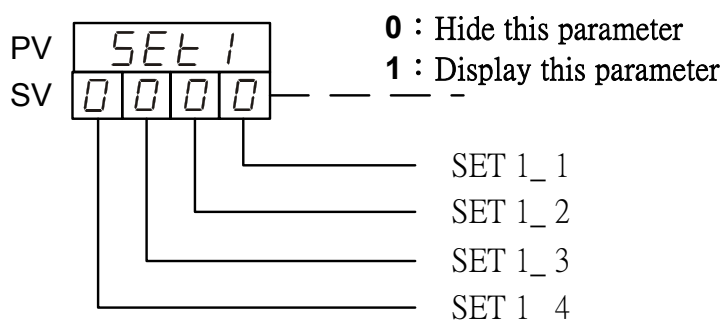

*For the description of Level 1 parameters, please refer with page 17.

*For the description of Level 3 parameters, please refer with page 20.

| SET | Display / hiding | Level | SET | Display / hiding | Level |
|-----|------------------|---------|-----|---------------------|---------|
| 1_1 | OUTL | Level 1 | 5_1 | CL02,CH02 | Level 3 |
| 1_2 | AL | Level 1 | 5_2 | CL03,CH03 | Level 3 |
| 1_3 | AL1 | Level 1 | 5_3 | FUCY,DATE,SEtA | Level 3 |
| 1_4 | AL2 | Level 1 | 5_4 | PSL,bits,Id.NO,bAUD | Level 3 |
| 2_1 | AL3 | Level 1 | 6_1 | SUDS | Level 3 |
| 2_2 | ANL1,ANH1,dP | Level 3 | 6_2 | PUDS | Level 3 |
| 2_3 | L.SPL,U.SPL | Level 3 | 6_3 | UNIT | Level 3 |
| 2_4 | ANL2,ANH2 | Level 3 | 6_4 | P'Ft | Level 3 |
| 3_1 | ALd1 | Level 3 | 7_1 | CRSC | Level 3 |
| 3_2 | ALt1 | Level 3 | 7_2 | DUd | Level 3 |
| 3_3 | ALd2 | Level 3 | 7_3 | OPAd | Level 3 |
| 3_4 | ALt2 | Level 3 | 7_4 | H = | Level 3 |
| 4_1 | ALd3 | Level 3 | | | |
| 4_2 | ALt3 | Level 3 | | | |
| 4_3 | HYSR | Level 3 | | | |
| 4_4 | CL01,CH01 | Level 3 | | | |

9.4.2 Special functions (Use SET8 / SET9 / SET0)

| SET 8 | | Remark |
|--------------|--------------------------------|--|
| 8_1 | 0 : Program not repeat | Only available for programmable controller |
| | 1 : Program repeat | |
| 8_2 | 0 : No power failure option | |
| | 1 : With power failure option | |
| 8_3 | 0 : Program starts from 0 | |
| | 1 : Program starts from PV | |
| 8_4 | 0 : Reserved (Don't change it) | |

| SET 9 | | Remark |
|--------------|------------------------------------|--|
| 9_1 | 0 : Reserved (Don't change it) | |
| 9_2 | 0 : Timer Unit = "Hour : Minute" | Only available for programmable controller |
| | 1 : Timer Unit = "Minute : Second" | |
| 9_3 | 0 : Disable transmission | Used for transmission output |
| | 1 : SV Transmission | |
| 9_4 | 0 : Disable transmission | |
| | 1 : PV Transmission | |

| SET 0 | | Remark |
|--------------|--|--|
| 0_1 | 0 : TTL Communication (Slave) | Used for TTL communication |
| | 1 : TTL Communication (Master) | |
| 0_2 | 0 : Hide parameter "RATE" | AL3 will be replaced by "RATE" |
| | 1 : Display parameter "RATE" | |
| 0_3 | 0 : Disable Remote SV function | Used for Remote SV function |
| | 1 : Enable Remote SV function | |
| 0_4 | 0 : use output relay "b" contact when motor valve closed | Used for 3 wire proportional motor valve control |
| | 1 : use output relay "a" contact when motor valve closed | |

Please don't operate **SET 8_4**, otherwise the controller's process will be in confusion.

If SET8.4 is set to "1", the controller will enter into "Single Display" mode, the PV LED will not display any values. The SV LED will display both the parameter value and the setting value alternately as shown in the diagram below.

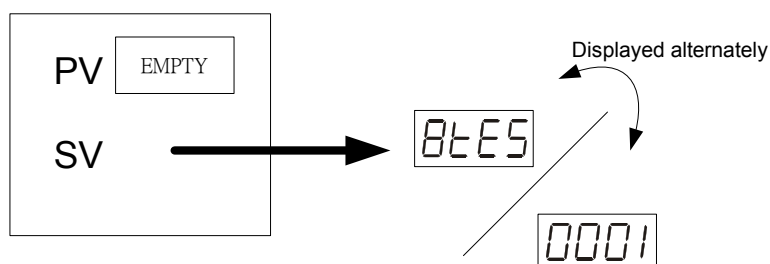

To rectify the problem please press the SHIFT KEY () and change the setting value to "0000".

9.4.3 Remote SV type selection

INP2=0 None

INP2=1 10~50mV / 4~20mA / 1~5V / 2~10V

INP2=2 0~50mV / 0~20mA / 0~5V / 0~10V

INP2=4 CT input

※Remote SV function is not available for programmable controller

9.4.4 Output mode selection (Use OUTY)

OUTY=0 Single output (OUT1)

OUTY=1 Dual output (OUT1 / OUT2)

OUTY=2 Reserved

OUTY=3 3 wire proportional motor valve control

OUTY=4 1 ψ Phase angle control (1 ψ SCR)

OUTY=5 3 ψ Phase angle control (3 ψ SCR)

9.4.5 Modify caution

If change parameter "BAUD", "BITS", "RUCY", "OUTY" the power must be reset

9.5 Program Level (Only displayed in programmable controller)

9.5.1 Description of parameters

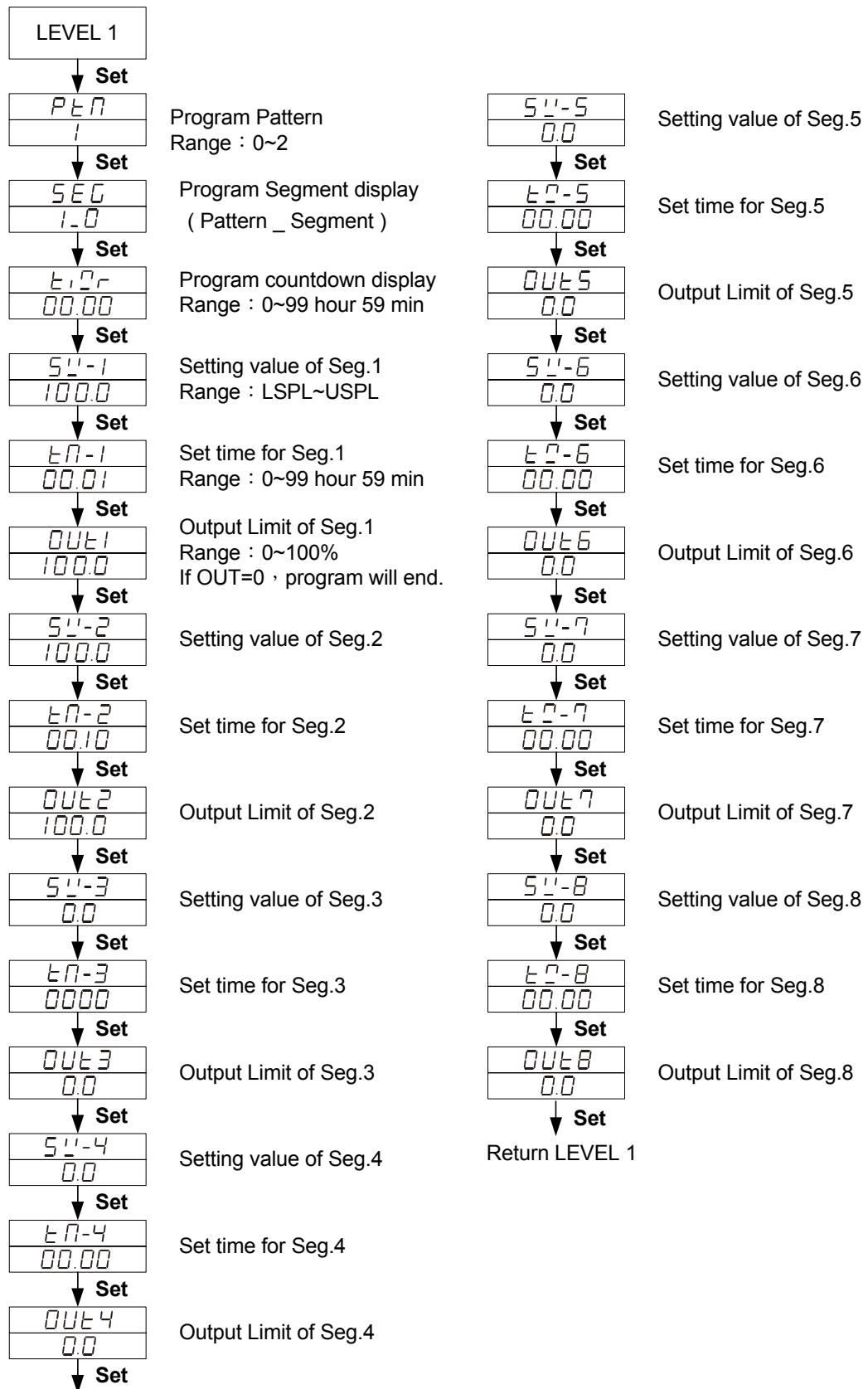

9.5.2 Description of operation

1. There are 2 patterns can be used , each pattern contains 8 segments.

2. Terminologies

Pattern : A program consists of some steps.

Ramp status : The status with changing SV.

Soak status : The status with fixed SV.

3. Operating

I. "KEY" function (no changing parameter)

△ (RUN) : Start program procedure , **PRO** LED in panel start flicking.

▽ (HOLD) : Suspend program procedure , **PRO** LED in panel will stop flicker but still light on.

△ + **SET**(JUMP) : Jump to previous segment.

▽ + **SET** (RESET) : Reset program procedure , **PRO** LED in panel will off.

II. Alarm Function :

ALD1 = "07"(Segment end alarm) ,

AL1 ="2"(It means when segment 2 end,AL1 will act) ,

ALT1 ="00:10" (Relay on time is 10 seconds).

* In this case , when program proceeds to segment 2 end , the relay of AL1 will be on 10 seconds.

III. END function :

The Controller doesn't have END order, so if program procedure is less than 8 segments, please set the last segments OUT to "0". Program will end in this segment. Otherwise , it will proceed 8 or 16 segments.

IV. Linking Function :

PTN=1 proceed pattern 1 , contains 8 segments.

PTN=2 proceed pattern 2 , contains 8 segments.

PTN=0 linking proceed pattern 1 and 2 totally 16 segments.

(Please set PTN1 and PTN2 at first , and then set PTN to 0)

V. Other function(* refer to LEVEL 4)

SET 8_1=1 Program repeats.

SET 8_2=0 No power failure function.

SET 8_2=1 Enable power failure function.

(When power shut down and on again , the controller will start from the segment which is near PV)

SET 8_3=0 Program starts from 0.

SET 8_3=1 Program starts from PV.

SET 9_2=0 Timer Unit = "Hour: Minute"

SET 9_2=1 Timer Unit = "Minute: Second"

10. Input type table (INP1 selection)

| TYPE | CODE | RANGE |
|-------------------|------------|-------------------------------------|
| K | <i>K1</i> | 0.0 ~ 200.0°C / 0.0 ~ 392.0°F |
| | <i>K2</i> | 0.0 ~ 400.0°C / 0.0 ~ 752.0°F |
| | <i>K3</i> | 0 ~ 600°C / 0 ~ 1112°F |
| | <i>K4</i> | 0 ~ 800°C / 0 ~ 1472°F |
| | <i>K5</i> | 0 ~ 1000°C / 0 ~ 1832°F |
| | <i>K6</i> | 0 ~ 1200°C / 0 ~ 2192°F |
| J | <i>J1</i> | 0.0 ~ 200.0°C / 0.0 ~ 392.0°F |
| | <i>J2</i> | 0.0 ~ 400.0°C / 0.0 ~ 752.0°F |
| | <i>J3</i> | 0 ~ 600°C / 0 ~ 1112°F |
| | <i>J4</i> | 0 ~ 800°C / 0 ~ 1472°F |
| | <i>J5</i> | 0 ~ 1000°C / 0 ~ 1832°F |
| | <i>J6</i> | 0 ~ 1200°C / 0 ~ 2192°F |
| R | <i>R1</i> | 0 ~ 1600°C / 0 ~ 2912°F |
| | <i>R2</i> | 0 ~ 1769°C / 0 ~ 3216°F |
| S | <i>S1</i> | 0 ~ 1600°C / 0 ~ 2912°F |
| | <i>S2</i> | 0 ~ 1769°C / 0 ~ 3216°F |
| B | <i>B1</i> | 0 ~ 1820°C / 0 ~ 3308°F |
| E | <i>E1</i> | 0 ~ 800°C / 0 ~ 1472°F |
| | <i>E2</i> | 0 ~ 900°C / 0 ~ 1652°F |
| N | <i>N1</i> | 0 ~ 1200°C / 0 ~ 2192°F |
| | <i>N2</i> | 0 ~ 1300°C / 0 ~ 2372°F |
| T | <i>T1</i> | -199.9 ~ 400.0°C / -199.9 ~ 752.0°F |
| | <i>T2</i> | -199.9 ~ 200.0°C / -199.9 ~ 392.0°F |
| | <i>T3</i> | 0.0 ~ 350.0°C / 0.0 ~ 662.0°F |
| W5Re/W26Re | <i>W1</i> | 0 ~ 2000°C / 0 ~ 3632°F |
| | <i>W2</i> | 0 ~ 2320°C / 0 ~ 4208°F |
| PL II | <i>PL1</i> | 0 ~ 1300°C / 0 ~ 2372°F |
| | <i>PL2</i> | 0 ~ 1390°C / 0 ~ 2534°F |
| U | <i>U1</i> | -199.9 ~ 600.0°C / -199.9 ~ 999.9°F |
| | <i>U2</i> | -199.9 ~ 200.0°C / -199.9 ~ 392.0°F |
| | <i>U3</i> | 0.0 ~ 400.0°C / 0.0 ~ 752.0°F |
| L | <i>L1</i> | 0 ~ 400°C / 0 ~ 752°F |
| | <i>L2</i> | 0 ~ 800°C / 0 ~ 1472°F |

| TYPE | CODE | RANGE |
|----------------------|-------------|-------------------------------------|
| JIS PT100 | <i>JP1</i> | -199.9 ~ 600.0°C / -199.9 ~ 999.9°F |
| | <i>JP2</i> | -199.9 ~ 400.0°C / -199.9 ~ 752.0°F |
| | <i>JP3</i> | -199.9 ~ 200.0°C / -199.9 ~ 392.0°F |
| | <i>JP4</i> | 0 ~ 200°C / 0 ~ 392°F |
| | <i>JP5</i> | 0 ~ 400°C / 0 ~ 752°F |
| | <i>JP6</i> | 0 ~ 600°C / 0 ~ 1112°F |
| DIN PT100 | <i>dP1</i> | -199.9 ~ 600.0°C / -199.9 ~ 999.9°F |
| | <i>dP2</i> | -199.9 ~ 400.0°C / -199.9 ~ 752.0°F |
| | <i>dP3</i> | -199.9 ~ 200.0°C / -199.9 ~ 392.0°F |
| | <i>dP4</i> | 0 ~ 200°C / 0 ~ 392°F |
| | <i>dP5</i> | 0 ~ 400°C / 0 ~ 752°F |
| | <i>dP6</i> | 0 ~ 600°C / 0 ~ 1112°F |
| JIS PT50 | <i>dP.1</i> | -199.9 ~ 600.0°C / -199.9 ~ 999.9°F |
| | <i>dP.2</i> | -199.9 ~ 400.0°C / -199.9 ~ 752.0°F |
| | <i>dP.3</i> | -199.9 ~ 200.0°C / -199.9 ~ 392.0°F |
| | <i>dP.4</i> | 0 ~ 200°C / 0 ~ 392°F |
| | <i>dP.5</i> | 0 ~ 400°C / 0 ~ 752°F |
| | <i>dP.6</i> | 0 ~ 600°C / 0 ~ 1112°F |
| AN1 | <i>AN1</i> | -10 ~ 10mV / -1999~9999 |
| AN2 | <i>AN2</i> | 0 ~ 10mV / -1999~9999 |
| AN3 | <i>AN3</i> | 0 ~ 20mV / -1999~9999 |
| AN4 | <i>AN4</i> | 0 ~ 50mV / -1999~9999 |
| AN5 | <i>AN5</i> | 10 ~ 50mV / -1999~9999 |

* The initial setting in factory is "K2".

11. Alarm

11.1 Alarm time (ALT1/ALT2/ALT3)

ALT1=0 Flicker alarm
ALT1=99.59 Continued alarm
ALT1=00.01 ~ 99.58 Alarm on delay time

11.2 SETA

*SETA is in Level 3 (Input level)

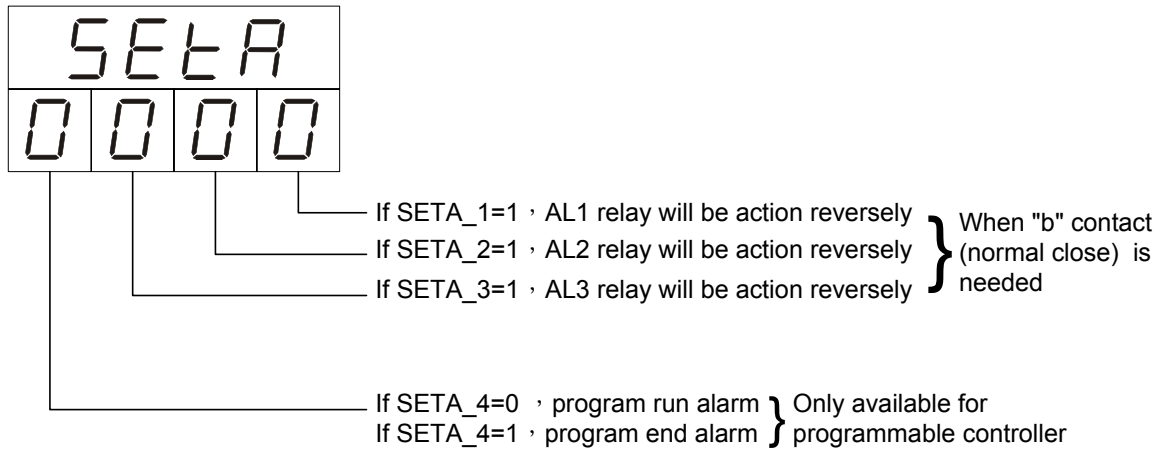

11.3 Alarm mode (ALD1 / ALD2 / ALD3)

(▲ :SV △ :Alarm set value)

| | |
|----------|---|
| 01 | Deviation high alarm with hold action* OFF ON ▲ △ HIGH → PV |
| 11 | Deviation high alarm OFF ON ▲ △ HIGH → PV |
| 02 | Deviation low alarm with hold action* ON OFF ▲ △ HIGH → PV |
| 12 | Deviation low alarm ON OFF ▲ △ HIGH → PV |
| 03 | Deviation high/low alarm with hold action* ON OFF ON LOW △ ▲ △ HIGH → PV |
| 13 | Deviation high/low alarm ON OFF ON LOW △ ▲ △ HIGH → PV |
| 04 14 | Band alarm OFF ON OFF LOW △ ▲ △ HIGH → PV |
| 05 | Process high alarm with hold action* OFF ON LOW △ HIGH → PV |
| 15 | Process high alarm OFF ON LOW △ HIGH → PV |

| | |
|----------|---|
| 06 | Process low alarm with hold action* ON OFF LOW △ HIGH → PV |
| 16 | Process low alarm ON OFF LOW △ HIGH → PV |
| 07 | Segment End alarm (Only for Programmable controller) (1) ALD1~3 , set 07 (2) ALD1~3=Alarm Segment (3) ALT1~3 defines as follows: 0 =flicker alarm 99.59 =continued alarm others =alarm ON time |
| 17 | Program Run alarm (Only for Programmable controller) Run Stop ON OFF AL |
| 08 | System failed alarm* (ON) Normal Failed OFF ON AL |
| 18 | System failed alarm* (OFF) Normal Failed ON OFF AL |
| 09 | Heater Break Alarm (HBA) Please refer with HBA Function Description in Page39 |
| 00 10 | No alarm |
| 19 | RAMP & SOAK If PV=SV, Alarm will delay for a while then (alarm set value) action. Range: 00.00~99.59(hr.min.) |

***Hold action:**

When Hold action is ON ,the alarm action is suppressed at start-up until the measured value(PV) enters the non-alarm range.

***System failed:**

It means that the controller display error message with one of following :
"UUU1" or "NNN1" or "CJCE"

12 Heater Break Alarm (HBA)

12.1 HBA Wiring Example

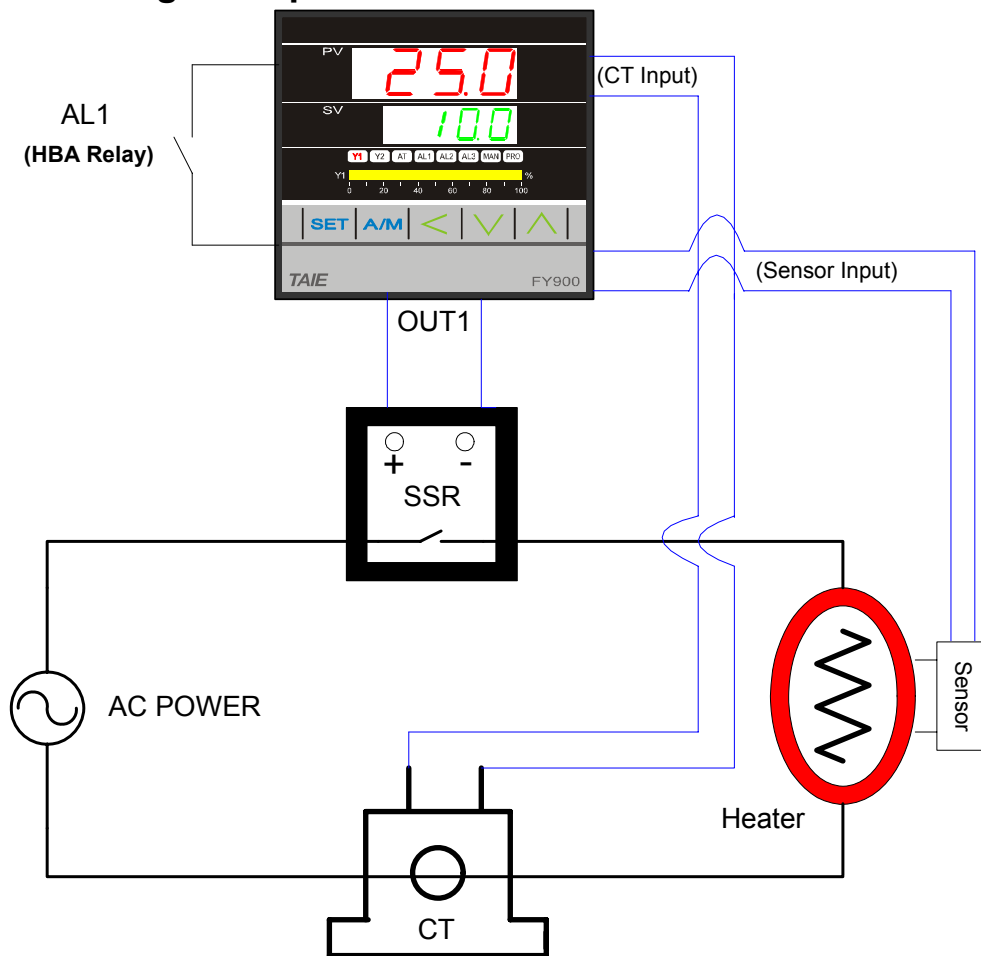

12.2 HBA Function Description

HBA function detects the AC current flowing through the heater by a Current Transformer (CT), and compares the CT input value and HBA set value. When OUT1 is ON and CT input value is less than HBA set value during 5 seconds, AL1 is activated. Otherwise, AL1 is not activated.

The AC current flowing through heater can also be monitored in HBA setting mode.

12.3 HBA setting procedure

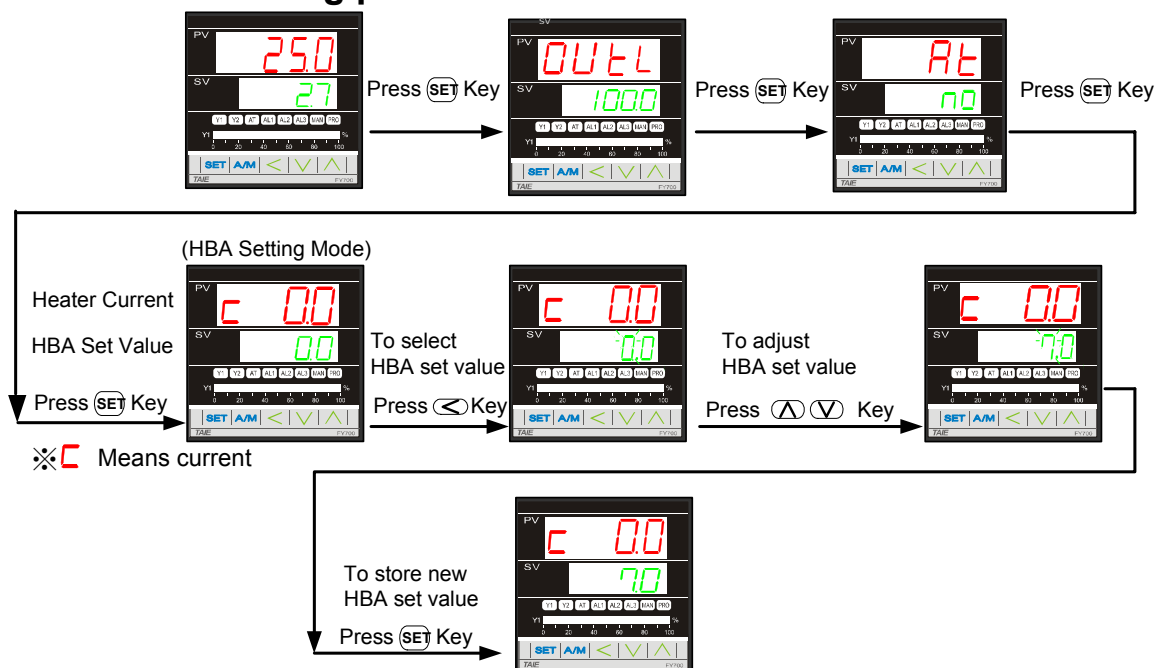

12.4 Parameters for HBA function

| Name | Value | Operation Level |
|------|---------------|-----------------|
| AL1 | HBA Set Value | Level 1 |
| ALD1 | 9 | Level 3 |
| SET0 | X1XX | Level 4 |
| INP2 | 4 | Level 4 |

- How to enter Level 3 : Set parameter “LCK” to 0000 in Level 2 , and then press “SET” key + “Shift” key 5 seconds to enter operation Level 3. ◦
- How to enter Level 4 : Set parameter “LCK” to 1111 in Level 2 , and then press “SET” key + “Shift” key 5 seconds to enter operation Level 4.
- ‘X’ value available 0 or 1

12.5 Activated conditions of HBA

| |
|---|
| Condition |
| 1. OUT1 is ON |
| 2. Heater current is less the HBA set value |
| 3. Condition1 and 2 continued more than 5 seconds |

AL1 will be activated, if condition 1&2&3 are all “true”.

12.6 Remarks

- Available output(OUT1) type for HBA
 - I. Relay
 - II. Voltage pulse (SSR drive)

- Since HBA function uses AL1 as alarm relay, please set temperature alarms in AL2 or AL3.

12.7 CT specifications

12.7.1 SC-80T Specifications

Rated Primary Current (Amp.) : 0.1A~80.0A

Turns Ratio : 800 : 1

D.C.Resistance Max.at 20 °C(Ω) : 45Ω

Accuracy (Linearity) : 3%

Dielectric Withstanding Voltage(Hi-pot) : 2500Vrms / 1 minute

Approx.Weight : 12g

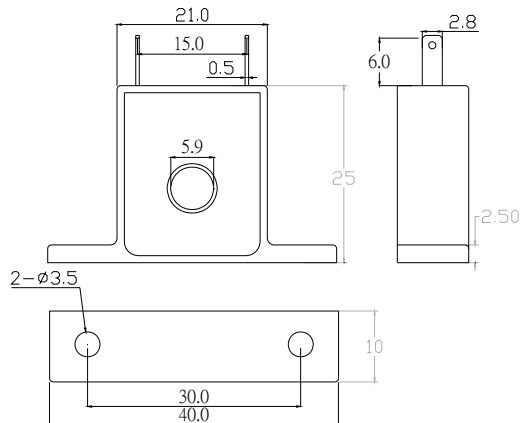

SC-80T Mechanical Dimensions (mm)

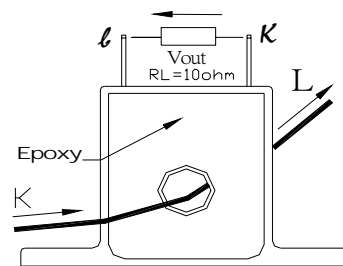

Test Circuit

12.7.2 SC-100T Specifications

Rated Primary Current (Amp.) : 0.1A~100.0A

Turns Ratio : 1000 : 1

D.C.Resistance Max.at 20 °C(Ω) : 150Ω

Accuracy (Linearity) : 3%

Dielectric Withstanding Voltage(Hi-pot) : 4000Vrms / 1 minute

Approx.Weight : 55g

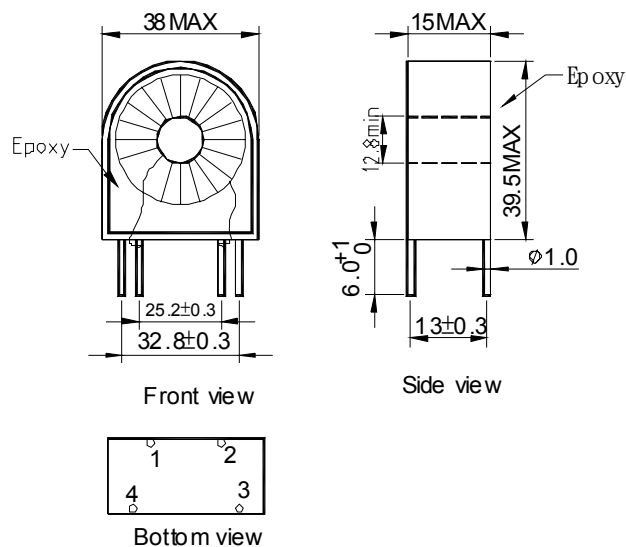

SC-100T Mechanical Dimensions (mm)

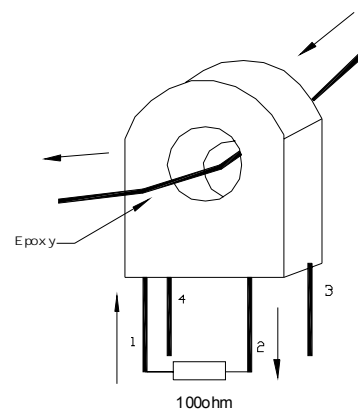

Test Circuit

11.7.3 SC-80T Linear Diagram

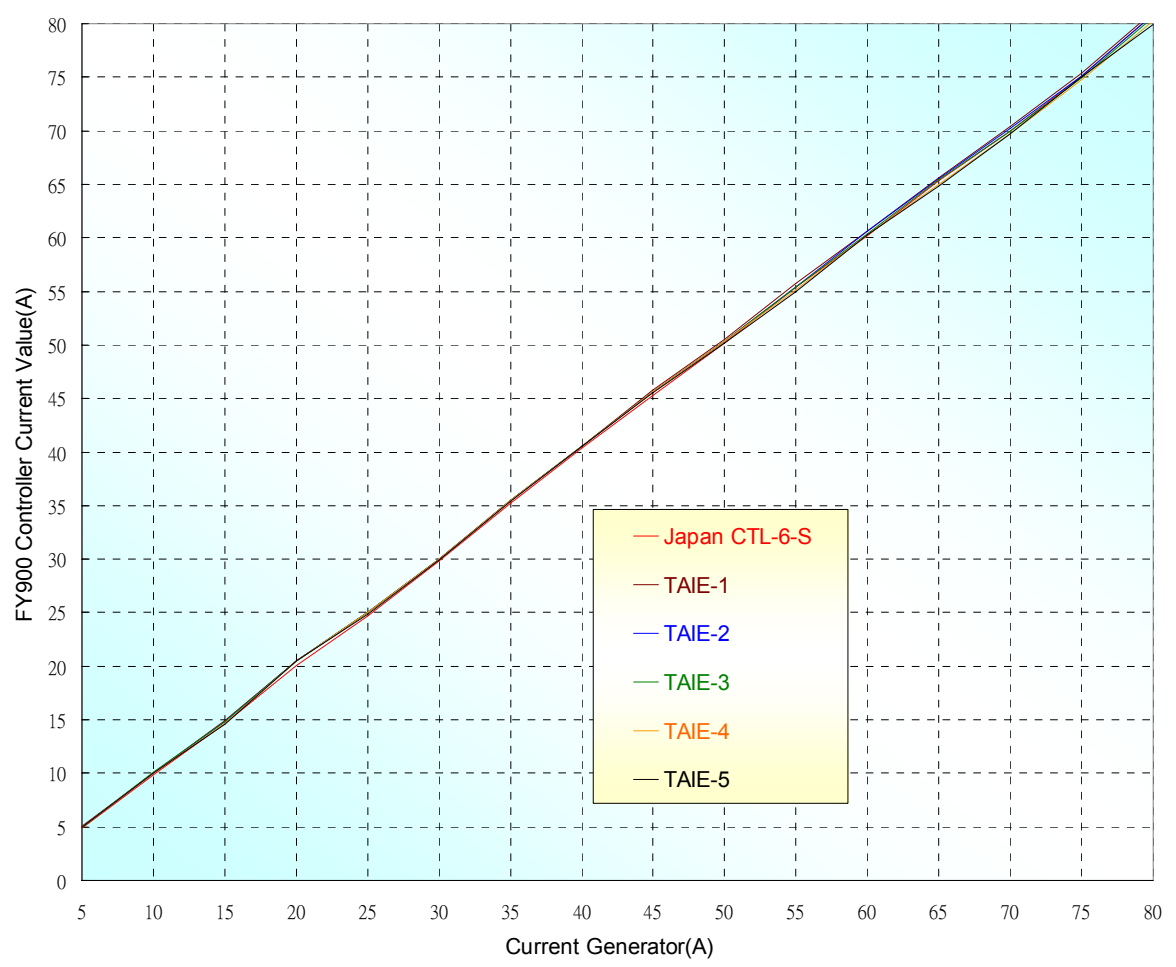

13. Error codes

| DISPLAY | DESCRIPTION |
|---------------|---|
| <i>in1E</i> | Open circuit of main control sensor.(INP1) |
| * <i>RdCF</i> | A/D convert failed. |
| * <i>CJCE</i> | Cold junction compensation failed. |
| <i>in2E</i> | Open circuit of sub control sensor.(Remote SV) |
| <i>uuu1</i> | PV exceeds USPL. |
| <i>nnn1</i> | PV under LSPL. |
| <i>uuu2</i> | Input signal of sub control exceeds the upper limit. (Remote SV) |
| <i>nnn2</i> | Input signal of sub control under the lower limit. (Remote SV) |
| * <i>HRDF</i> | RAM failed. |
| <i>intF</i> | Interface failed. |
| <i>AUeF</i> | Auto tuning failed. |

NOTE : If the “*” marked error comes up , the controller needs to be repaired.
Please send it to the nearest sales office or retail dealer.

FY400 TC_Pt100 Switch Jumper Site Plan

*Note : Please change the input type at the display menu when you finished the jumper switch.

1. Keep controller flat, LED display forwards

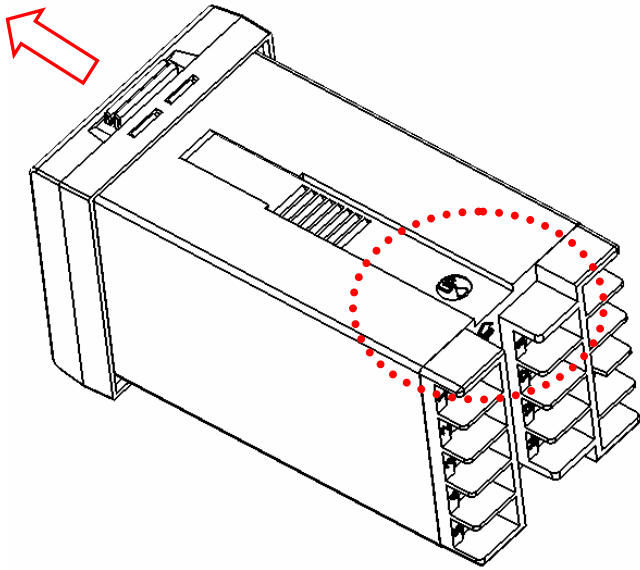

2. Pull out controller, jumper is below the CPU

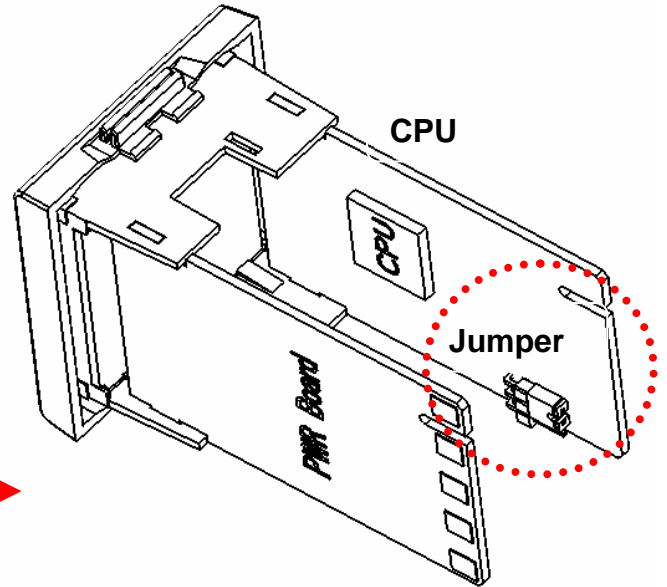

3. Turn the Power board up

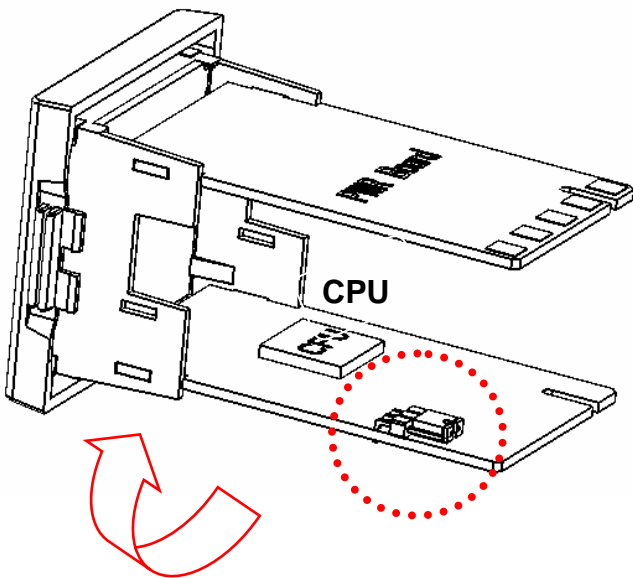

4. Sensor Input TC. Jumper insert the right site

K. J. R. S. B. E. N. T. W. P. L. I. I. U. L.

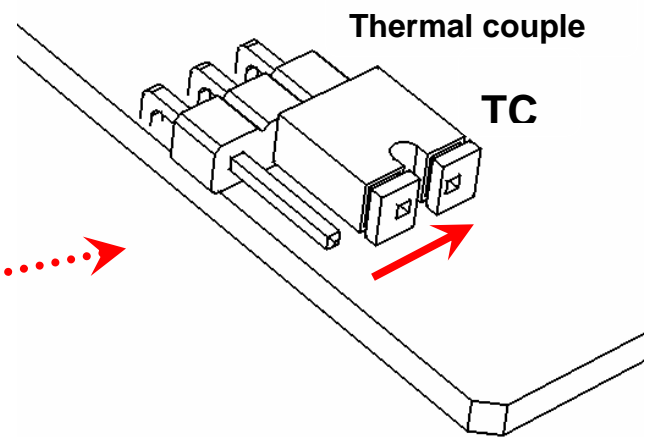

5. Change Sensor input, pull the Jumper out

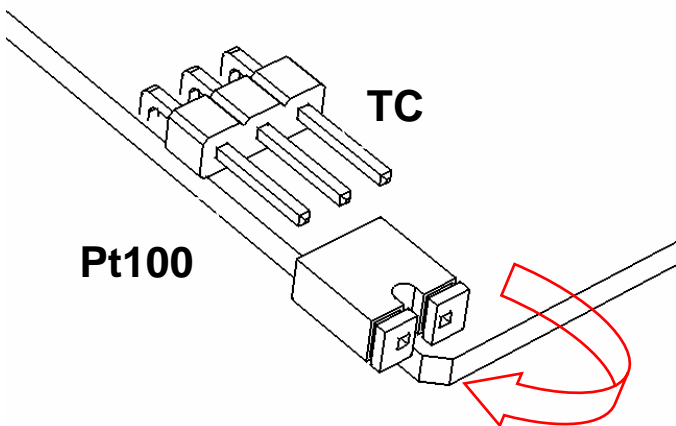

6. Sensor Input Pt100. Jumper insert the left site

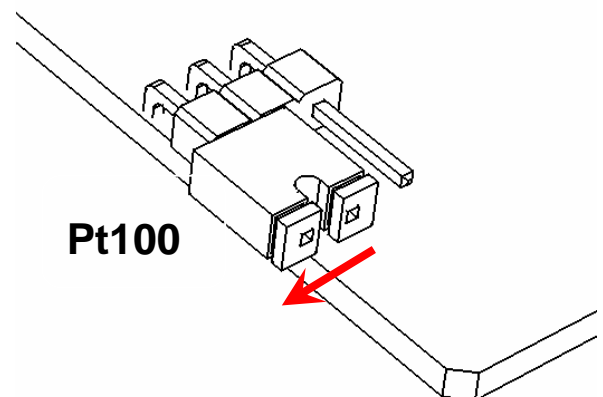

FY600/700/800/900 TC_Pt100 Switch Jumper Site Plan

*Note : Please change the input type at the display menu when you finished the jumper switch.

1. Keep controller flat, LED display forwards

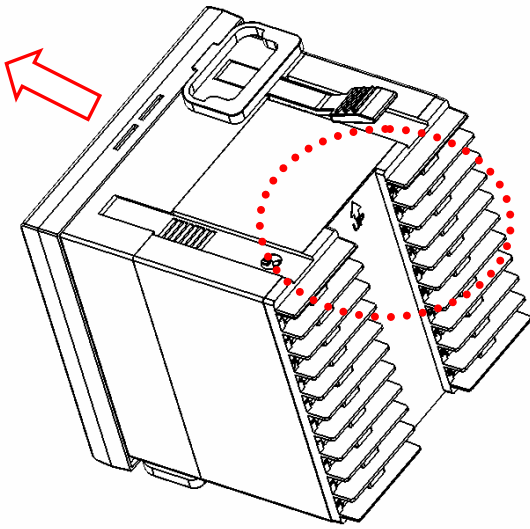

2. Pull out controller, jumper is below the CPU

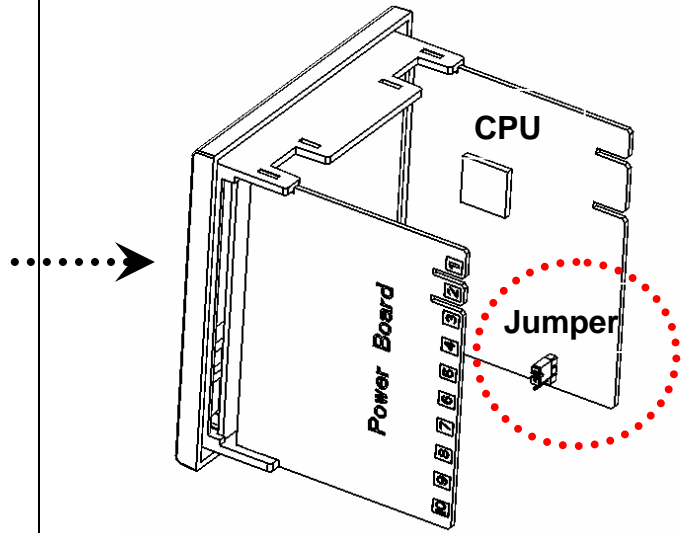

3. Turn the Power board up

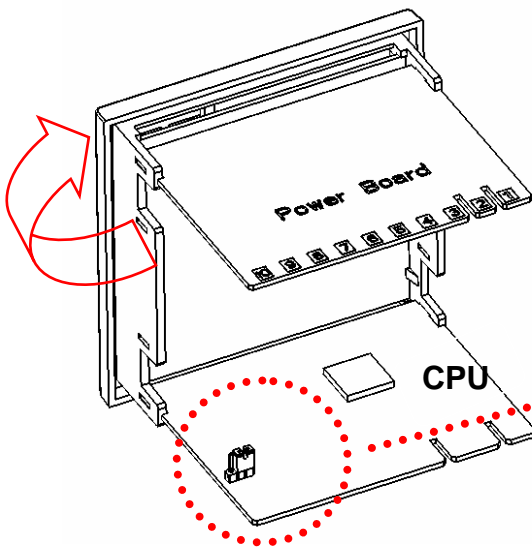

4. Sensor Input TC. Jumper insert the right site

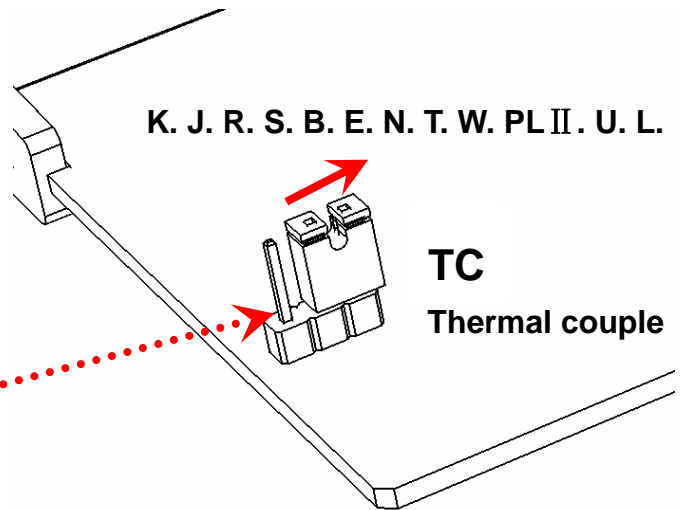

5. change Sensor input, pull the Jumper out

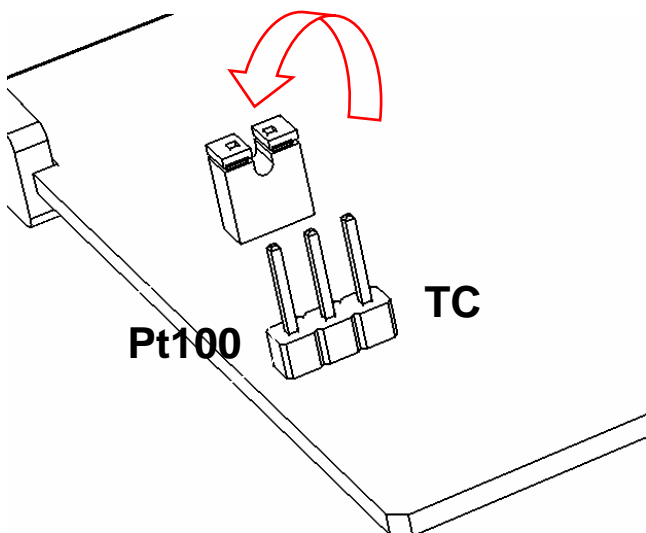

6. Sensor Input Pt100. Jumper insert the left site

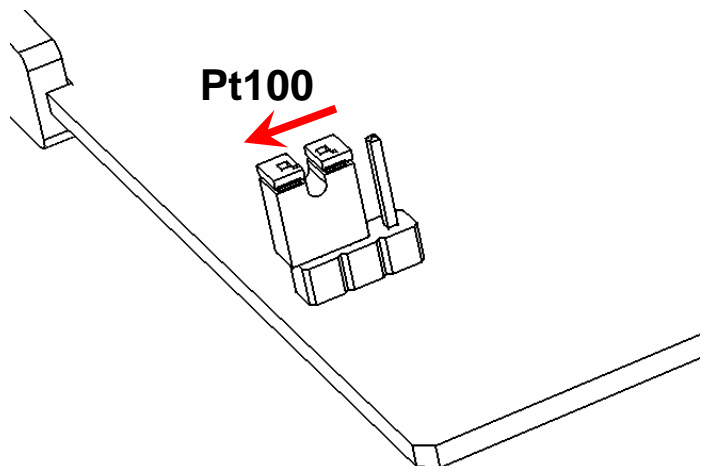

14.2 FU48~96

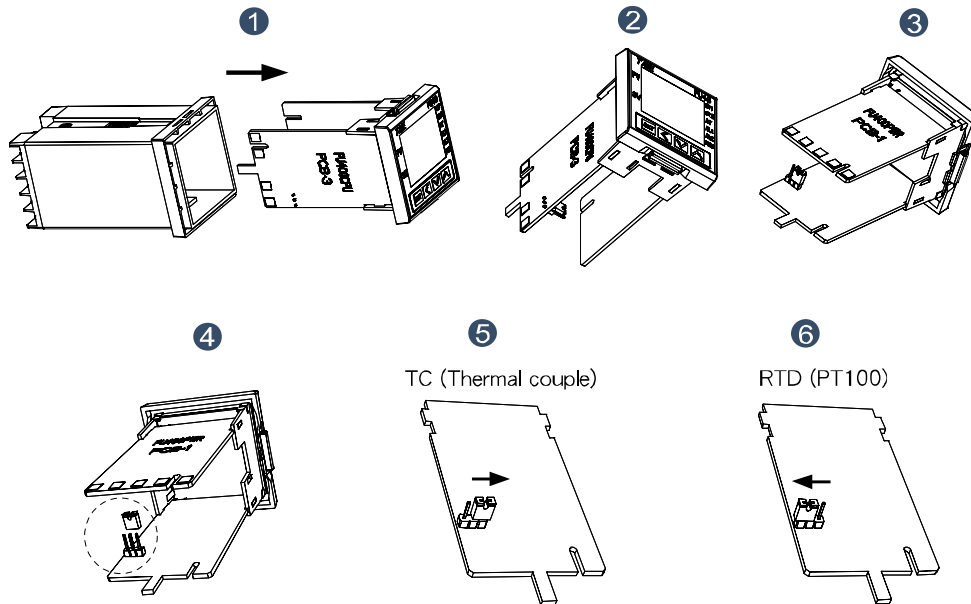

1. Take out the main body from outer case: adjust the jumper to the correct place.
2. Start power after setting jumper to the correct place.
3. Amend the input type from the front membrane to enter in Level 3 to set.
4. Please be sure to cut off power and start again after amending input type so that the new parameters could be effective.
5. To change input type of TC or RTD is available but linear input is unavailable. Please ask our local distributor for help.

14.3 FY100~FY101

If the controller needs to modify input type from **TC** or **mV** to **RTD**, please make PAD short on the back side of PC board as following diagram and change input selection(INP1). On the contrary, modify from **RTD** to **TC** or **mV**, make PAD open.

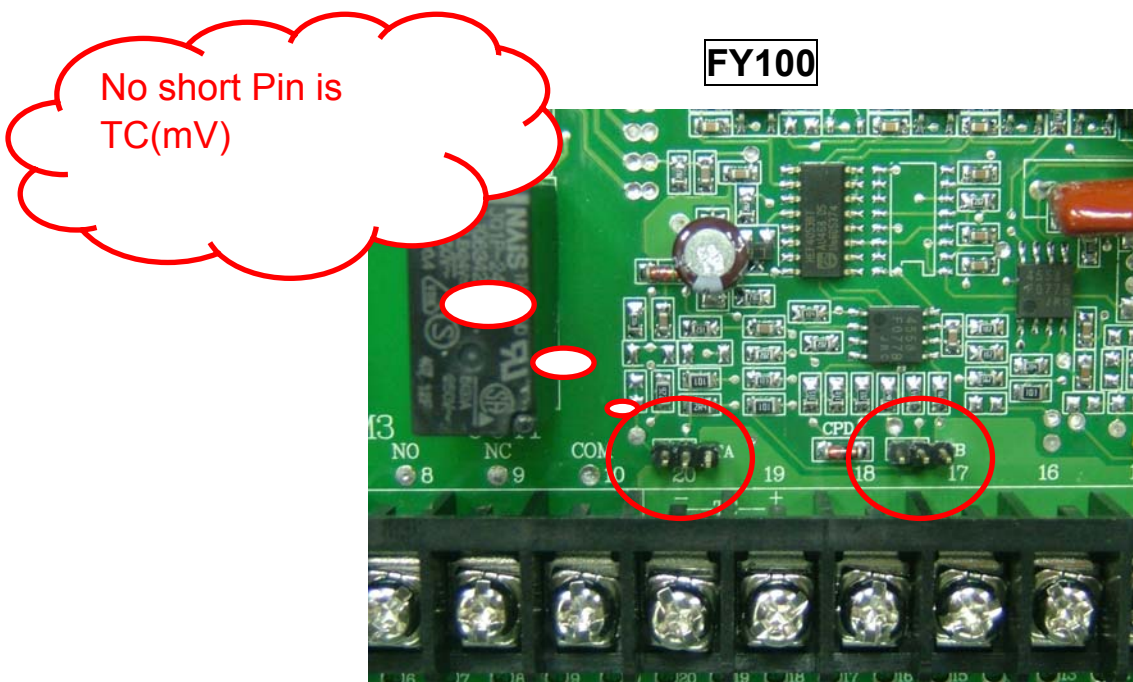

RTD

Short pin insert to **left**

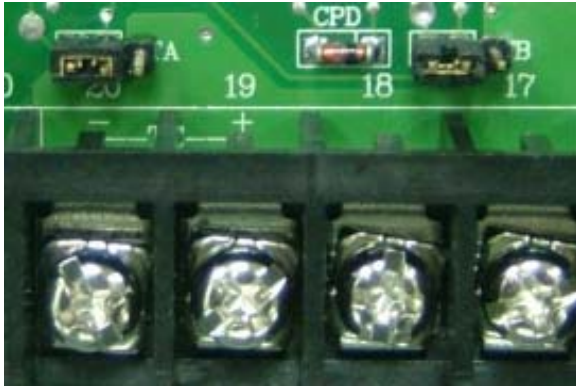

TC or mV

Short pin insert to **right or remove**



If the controller needs to modify input type from **TC or mV** to **RTD**, please make PAD short on the back side of PC board as following diagram and change input selection(INP1). On the contrary, modify from **RTD** to **TC or mV**, make PAD open.

FY101

TC or mV

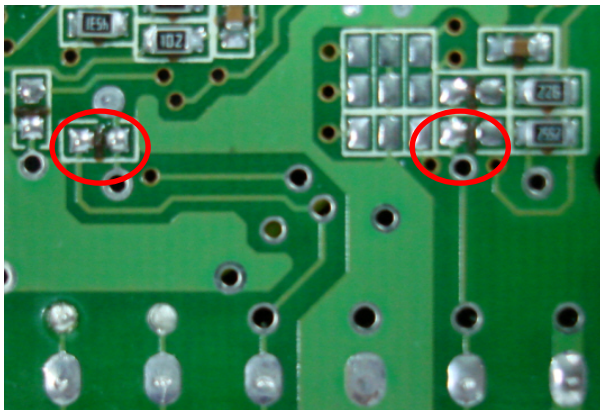

RTD

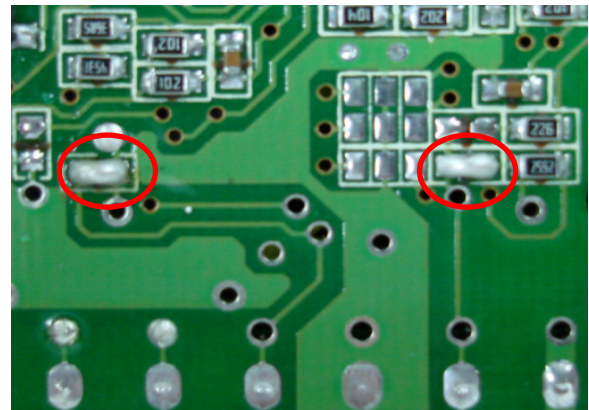

15. Modify input type : Linear Input (mA ,V)

15.1 FY400~900 & FU48~96 Hardware :

| | FY900 , FY600 , FY800 FU86 , FU96 | FY700 FU72 | FY400 FU48 |
|-------------|--------------------------------------|---------------|---------------|
| INPUT (+) | PIN 17 | PIN 11 | PIN 7 |
| INPUT (-) | PIN 20 | PIN 14 | PIN 10 |

0~20mA (INP1=AN4) : (R3 use 100Ω , R5 use 2.4Ω , S3 & S5 SHORT)

4~20mA (INP1=AN5) : (R3 use 100Ω , R5 use 2.4Ω , S3 & S5 SHORT)

0 ~ 1V (INP1=AN4) : (R1 use 2KΩ , R4 use 100Ω , S1 & S4 SHORT)

0 ~ 5V (INP1=AN4) : (R2 use 10KΩ , R4 use 100Ω , S2 & S4 SHORT)

1 ~ 5V (INP1=AN5) : (R2 use 10KΩ , R4 use 100Ω , S2 & S4 SHORT)

0 ~ 10V (INP1=AN4) : (R3 use 22KΩ , R4 use 100Ω , S3 & S4 SHORT)

2 ~ 10V (INP1=AN5) : (R3 use 22KΩ , R4 use 100Ω , S3 & S4 SHORT)

FY600 , FY800 , FY900 & FU86, FU96

(CPU Board)

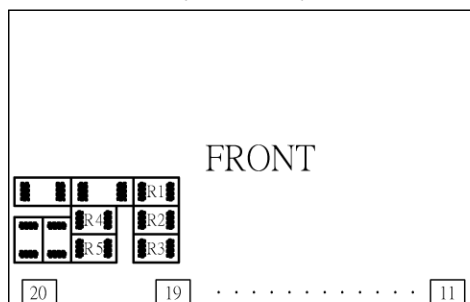

(CPU Board)

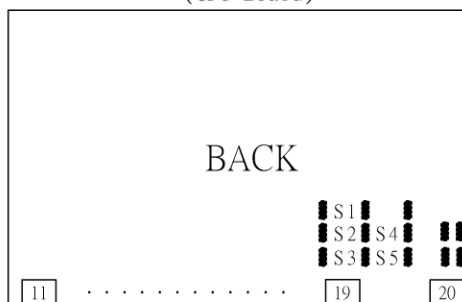

(CPU Board)

FY700 & FU72

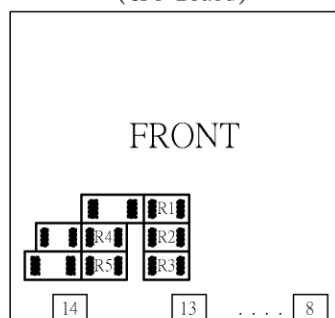

(CPU Board)

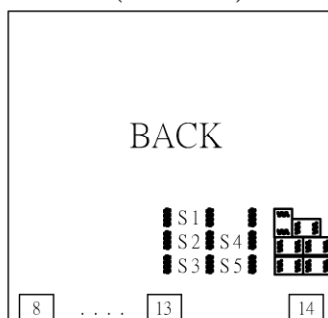

(CPU Board)

FY400 & FU48

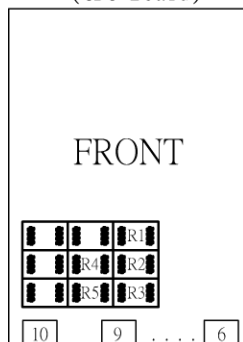

(CPU Board)

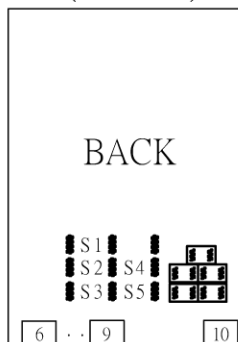

15.2 FY100/101 Hardware :

| | FY100 | FY101 |
|-------------|--------|--------|
| INPUT (+) | PIN 14 | PIN 10 |
| INPUT (-) | PIN 11 | PIN 8 |

0~20mA (INP1=AN4) : (R3 use 100Ω , R5 use 2.4Ω , S3&S5 SHORT)

4~20mA (INP1=AN5) : (R3 use 100Ω , R5 use 2.4Ω , S3&S5 SHORT)

0 ~ 1V (INP1=AN4) : (R1 use 2KΩ , R4 use 100Ω , S1 & S4 SHORT)

0 ~ 5V (INP1=AN4) : (R2 use 10KΩ , R4 use 100Ω , S2 & S4 SHORT)

1 ~ 5V (INP1=AN5) : (R2 use 10KΩ , R4 use 100Ω , S2 & S4 SHORT)

0 ~ 10V (INP1=AN4) : (R3 use 22KΩ , R4 use 100Ω , S3 & S4 SHORT)

2 ~ 10V (INP1=AN5) : (R3 use 22KΩ , R4 use 100Ω , S3 & S4 SHORT)

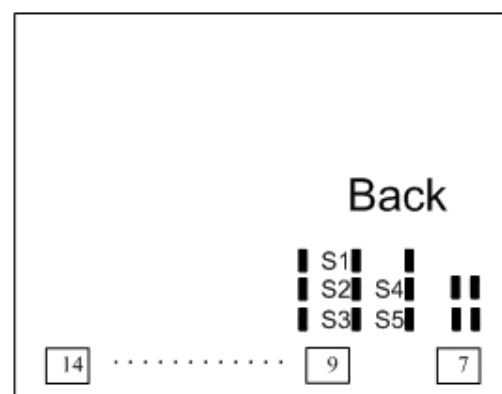
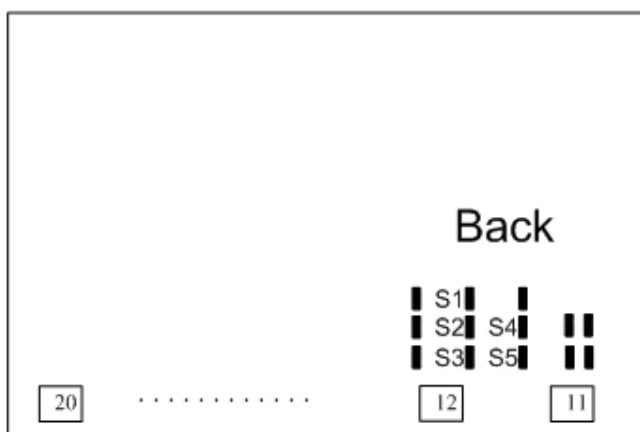
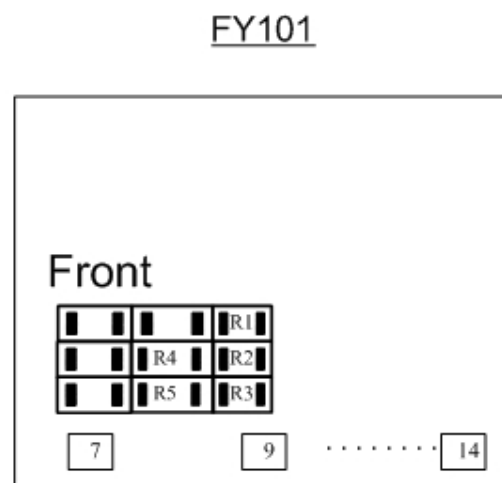
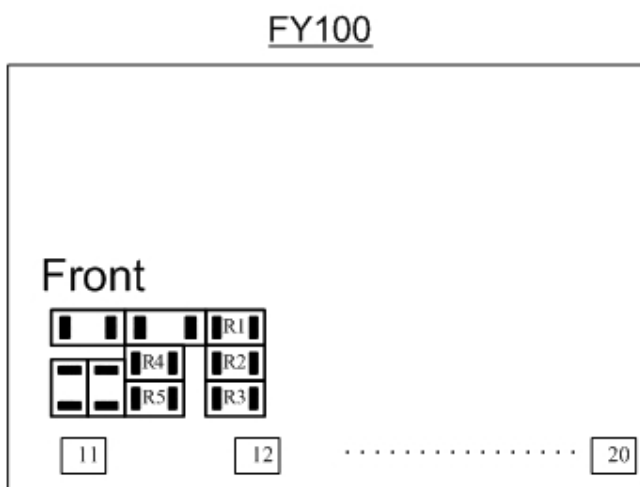

15.3 Calibration :

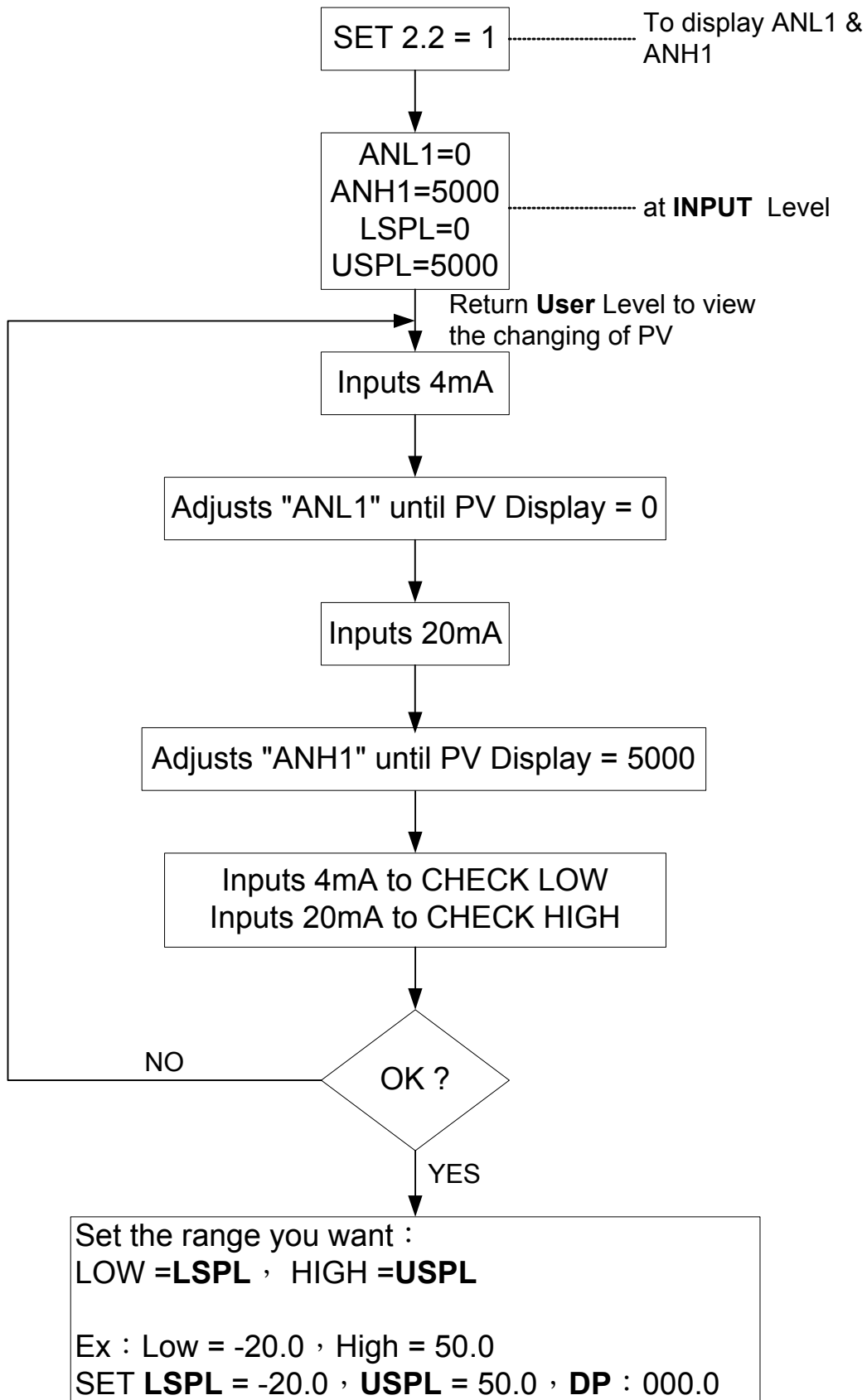

16. Modify Output type: Relay, SSR, 4~20mA

It just needs to change a module at the same position , and modify parameter **CYT1** in LEVEL 2 .

→Relay: CYT1=10, Voltage pulse: CYT1=1, 4~20mA:CYT1=0

17. Modify output mode: OUT1/ALARM, OUT1/OUT2

OUT1 / ALARM

FY600 , FY800 , FY900

(CPU Board)

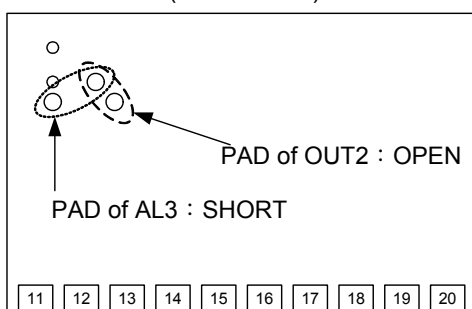

OUT1 / OUT2

FY600 , FY800 , FY900

(CPU Board)

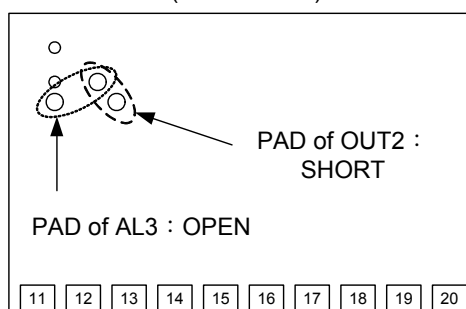

FY700

(CPU Board)

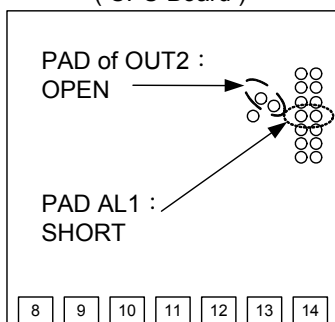

FY700

(CPU Board)

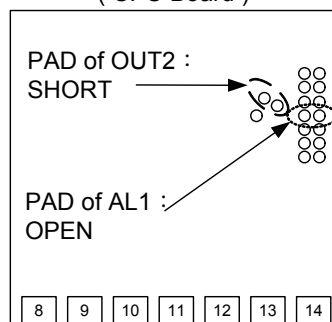

FY400

(CPU Board)

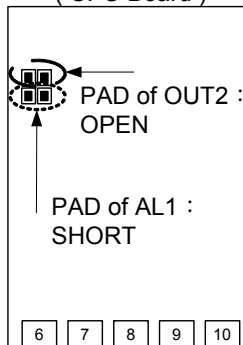

FY400

(CPU Board)

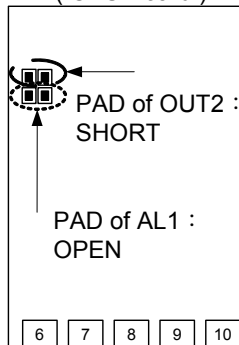

18. Applications

18.1 RAMP & SOAK

- **RAMP :**

- I. SET2.1=1 → To display AL3
- II. SET4.1=1 → To display ALD3
- III. ALD3=9 → Open RAMP option
- IV. Then, AL3 will not display. It was replaced by RAMP.

| |
|-------|
| RAMP |
| 00.00 |

Range : 00.00 ~ 99.99(°C/ min)
 (If RAMP is not used , please set
 ALD3 to 0)

- **SOAK :**

- I. ALD1 / ALD2=19 → To use Sock Timer.
- II. AL1 / AL2 will display as below:

| |
|-------|
| AL1 |
| 00.00 |

Range : 00.00 ~ 99.59(Hour.Minute)

- **Example :**

SV=100°C , RAMP=10.00 (°C/min) , AL1=00.10 min , PV=25°C

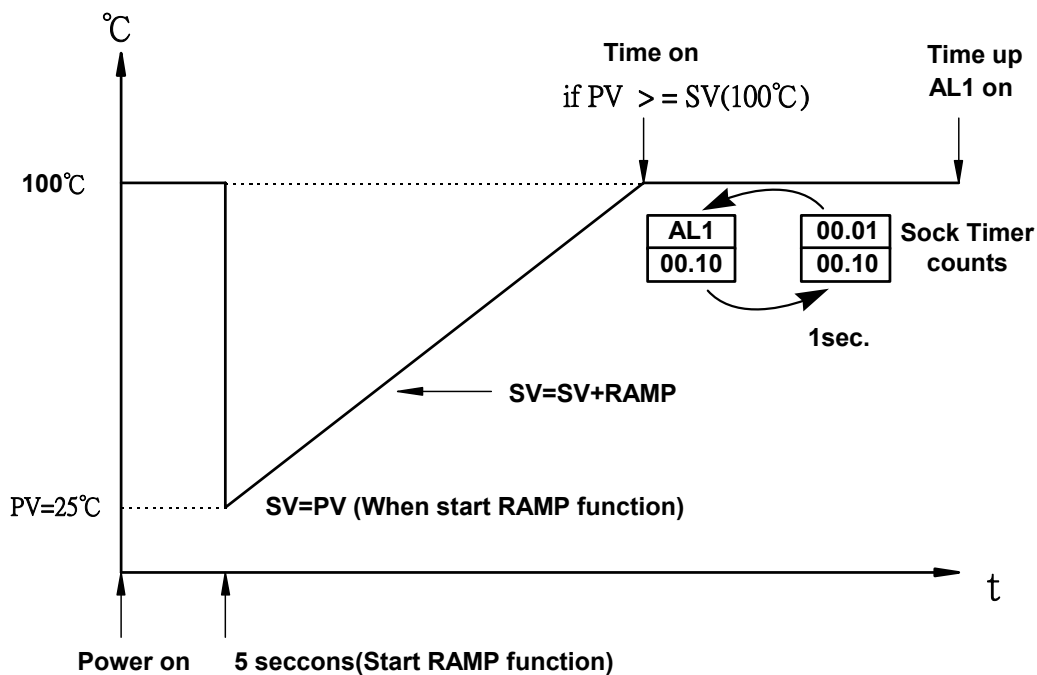

18.2 TTL Communication : SV output and RATE function

- **Open RATE function (use for slave controller)**

Display AL3 : SET2.1=1

Display ALD3 : SET4.1=1

Display RATE(AL3 will be replaced) : SET0.2=1

Set ALD3 to 0. (In Level 3)

Slave SV = (RATE÷9999)×master SV

- **Example :**

Connection Diagram

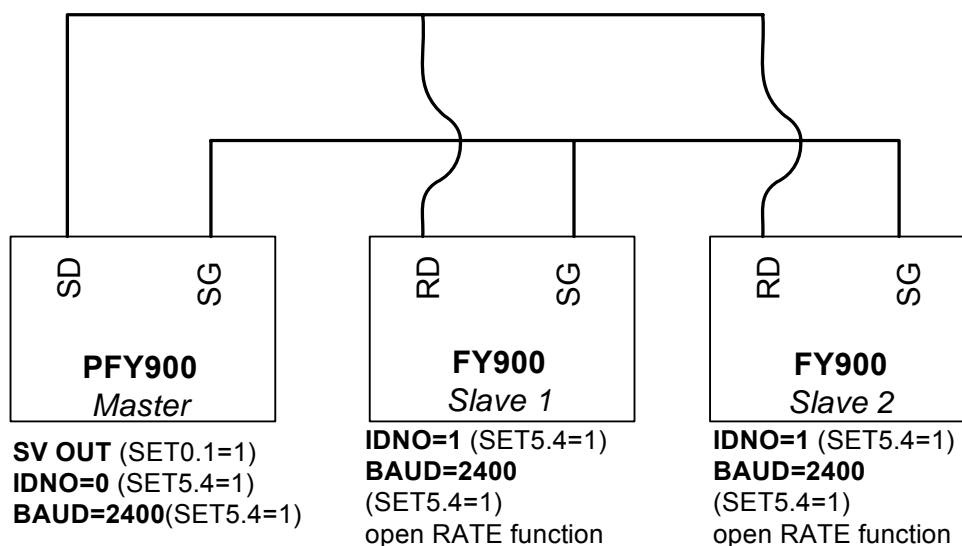

Time Chart

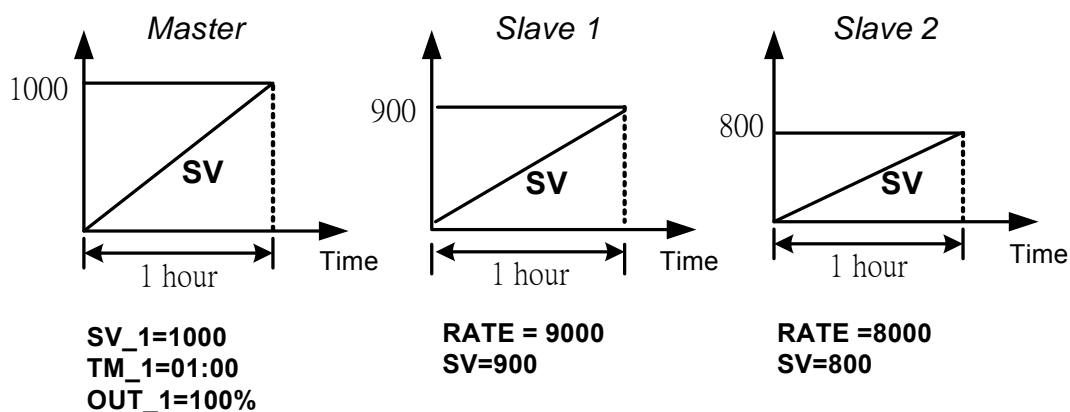

(Three controllers reach to the max value at the same time)

18.3 1 ϕ Phase angle control (By SCR module)

- Available Models : FY900 / PFY900 , FY700 / PFY700 , FY800 / PFY800
FY100 / PFY100
- OUT1: 1 ϕ SCR phase angle control
- Parameter setting : OUTY=4
CLO1=0 , CHO1=4500 if use for resistance load
CLO1=0 , CHO1=4000 if use for inductor load

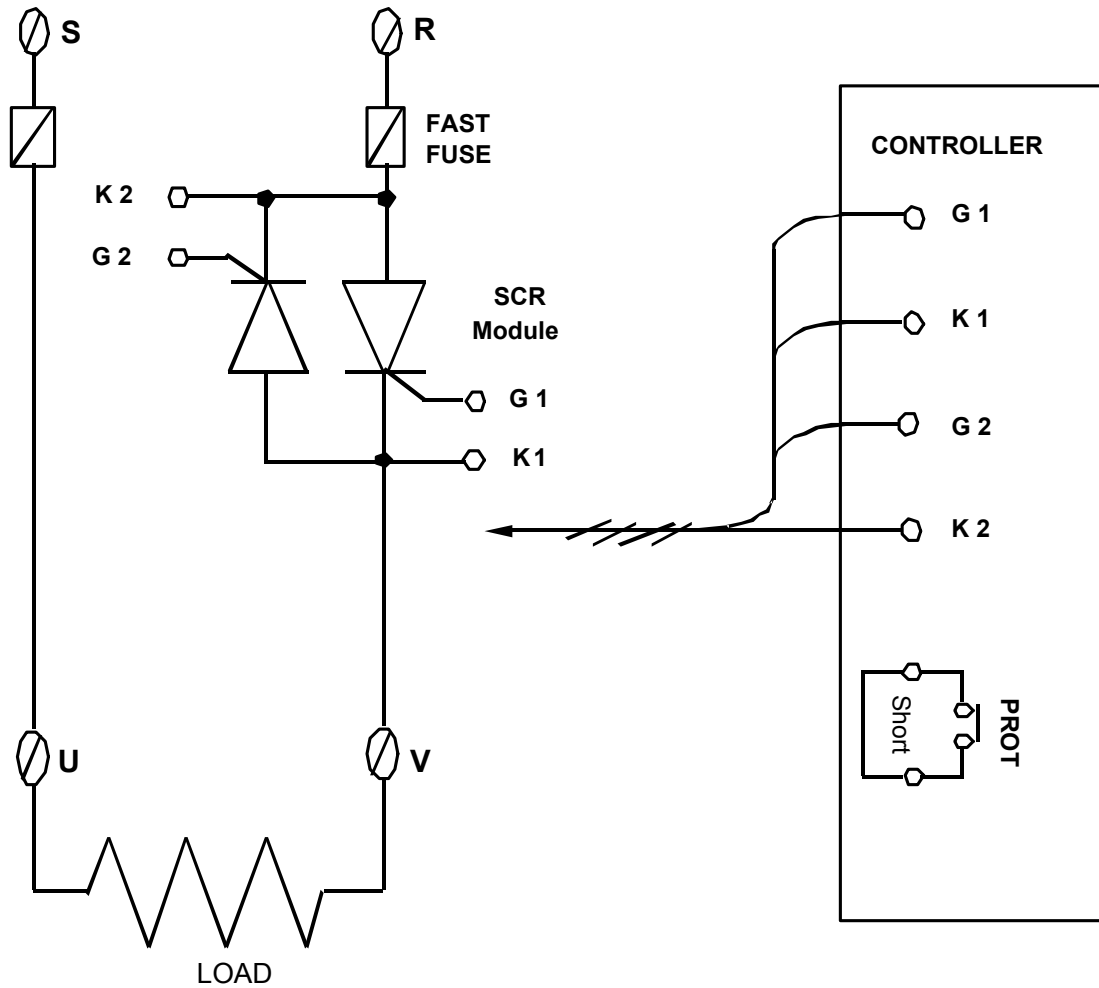

** Controller source phase must be same as load source phase

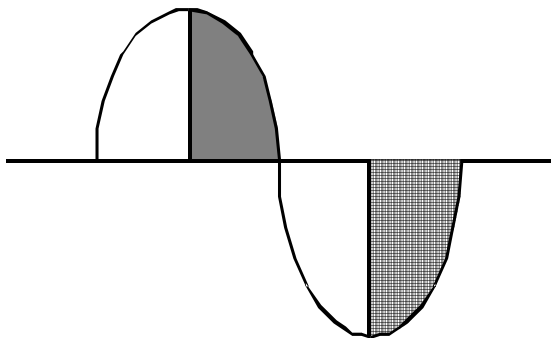

18.4 1 ϕ Phase angle control (By TRIAC)

- Available Models : FY900 / PFY900 , FY700 / PFY700 , FY800 / PFY800
FY100 / PFY100
- OUT1: 1 ϕ SCR phase angle control
- Parameter setting : OUTY=4
CLO1=0 , CHO1=4500 if use for resistance load
CLO1=0 , CHO1=4000 if use for inductor load

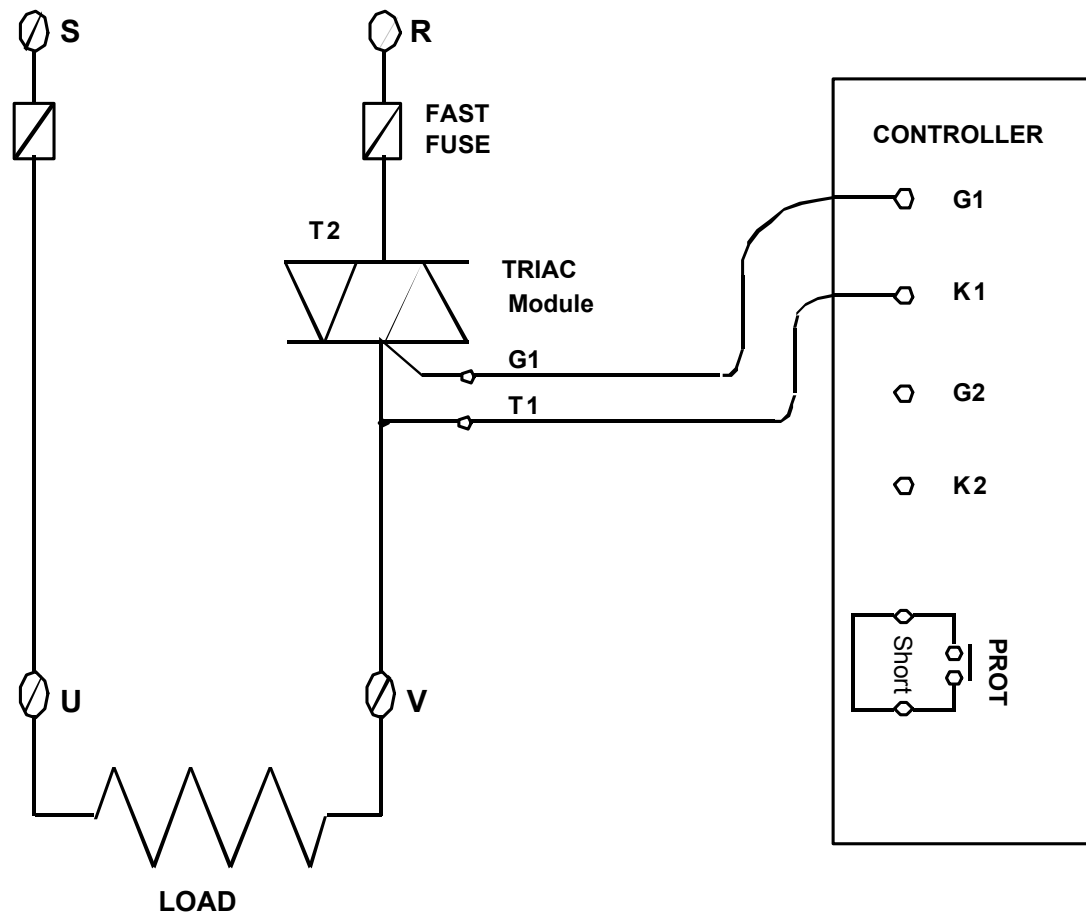

** Controller source phase must be same as load source phase

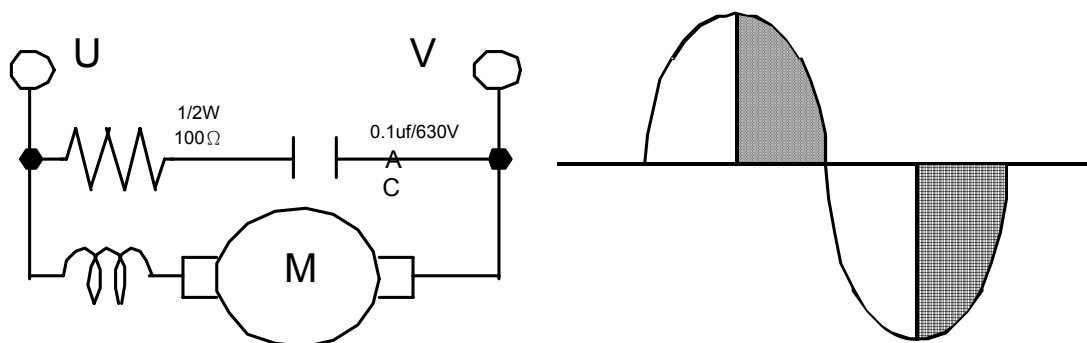

18.5 3 ϕ Phase angle control (By DIODE/SCR module)

- Available Models : FY900 / PFY900
- OUT1: 3 ϕ SCR phase angle control
- Parameter setting : OUTY=5
 CLO1=0 , CHO1=4500 only if use for resistance load
 CLO1=0 , CHO1=4000 if use for inductor load

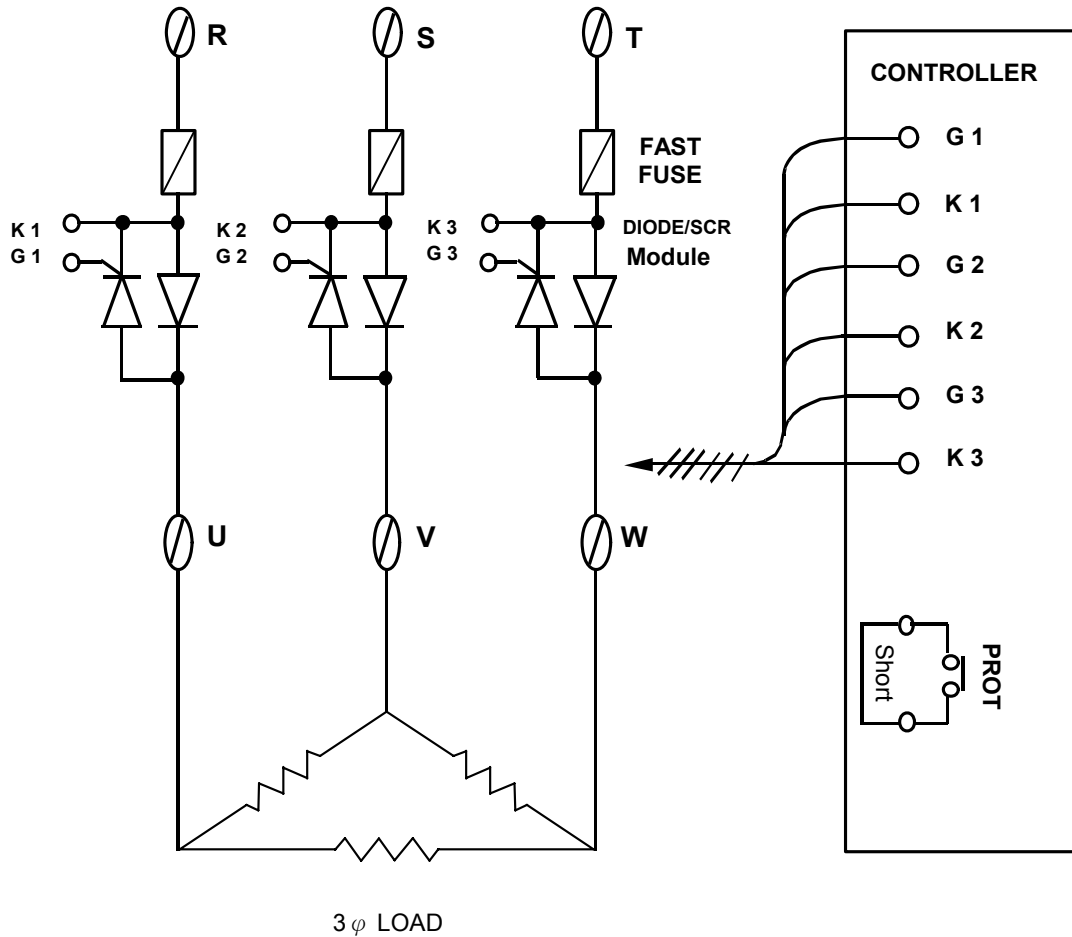

18.6 1 ϕ Zero crossing control (By SCR module)

- Available Models : FY900 / PFY900 , FY700 / PFY700
FY400 / PFY400
- OUT1: 1 ϕ SCR zero cross control
- Parameter setting : OUTY=0
CYT1=1

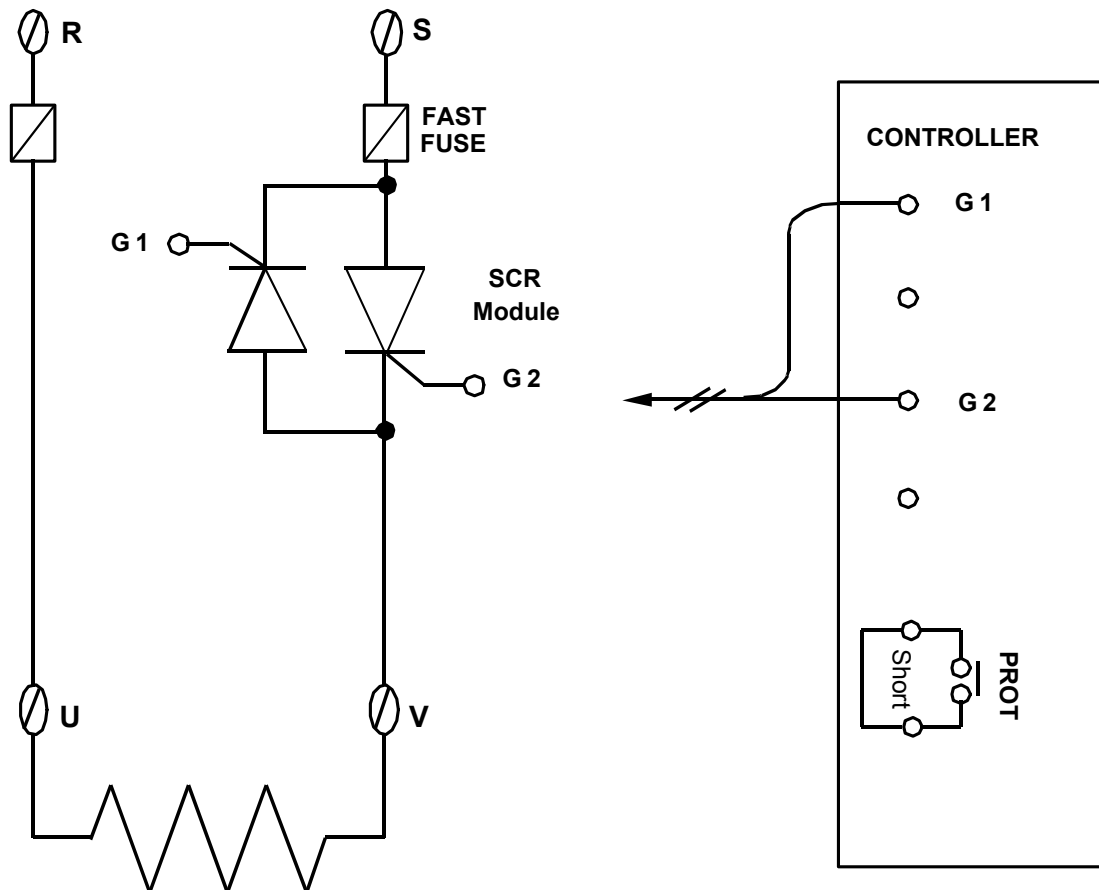

TIME CHART:

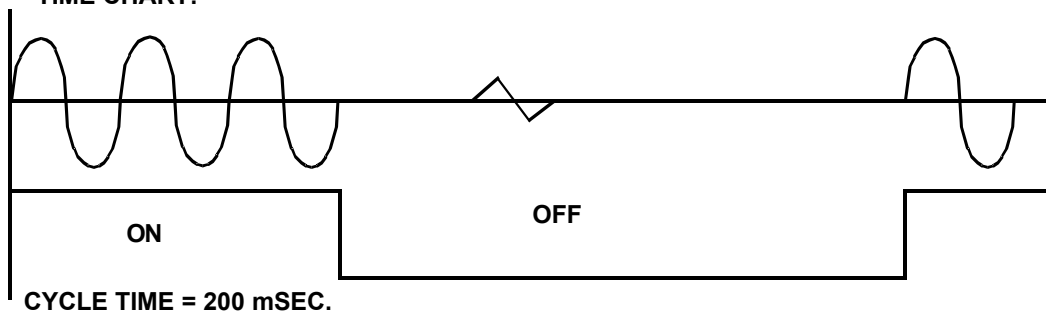

18.7 1 ϕ Zero crossing control (By TRIAC)

- Available Models : FY900 / PFY900 , FY700 / PFY700
FY400 / PFY400
- OUT1: 1 ϕ SCR zero cross control
- Data Change : OUTY=0
CYT1=1

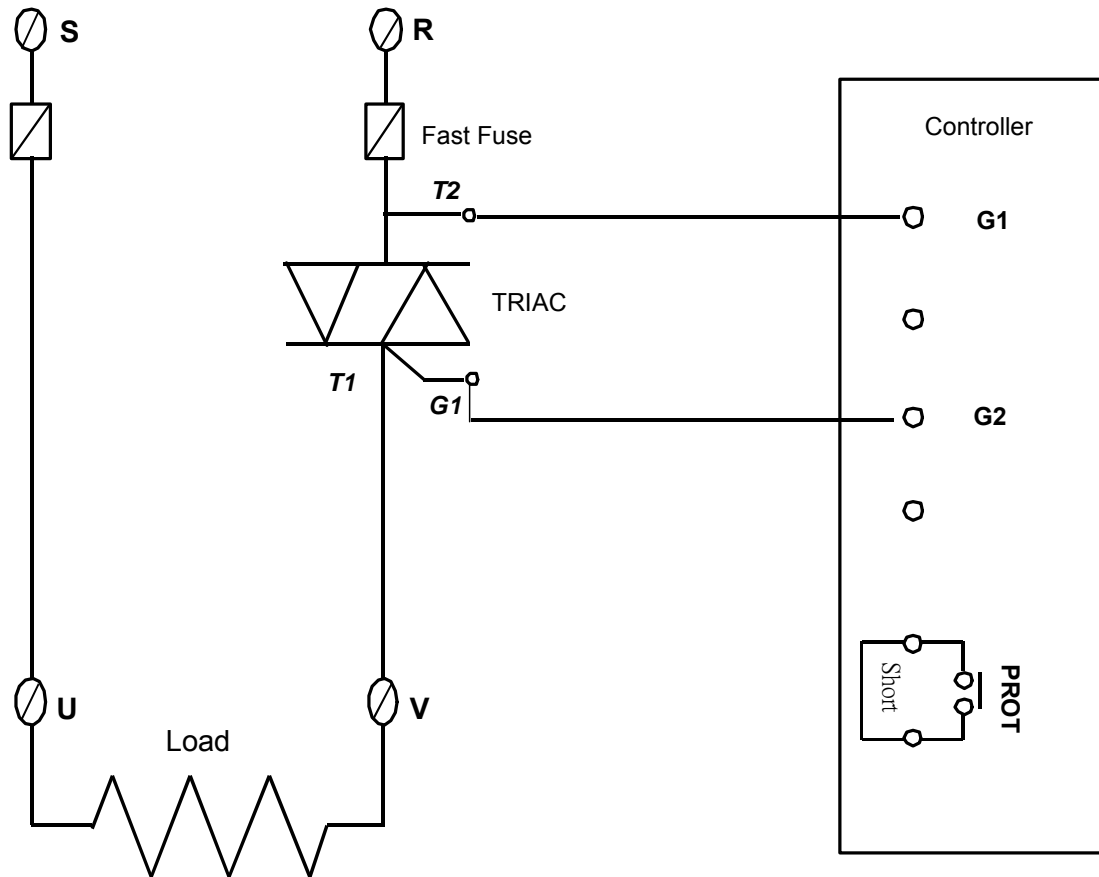

18.8 3 ϕ Zero crossing control (By SCR module)

- Available Models : FY900 / PFY900
- OUT1: 3 ϕ SCR zero cross control
- Data Change : OUTY=0
CYT1=1

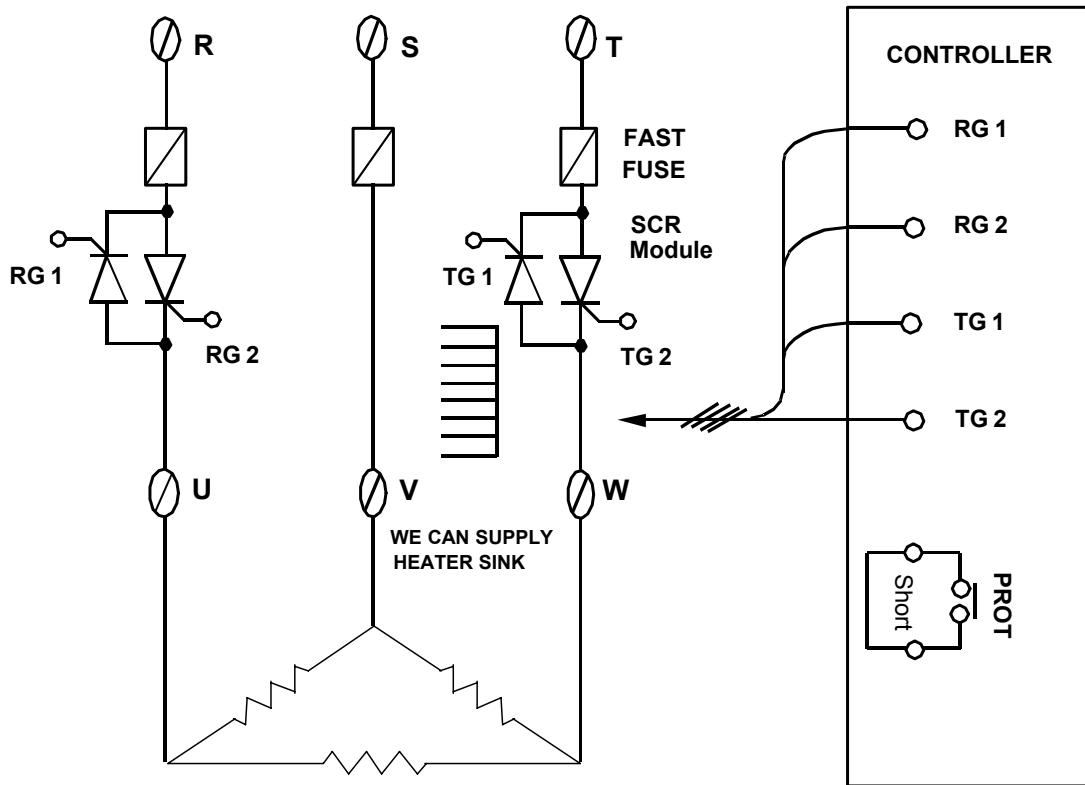

TIME CHART:

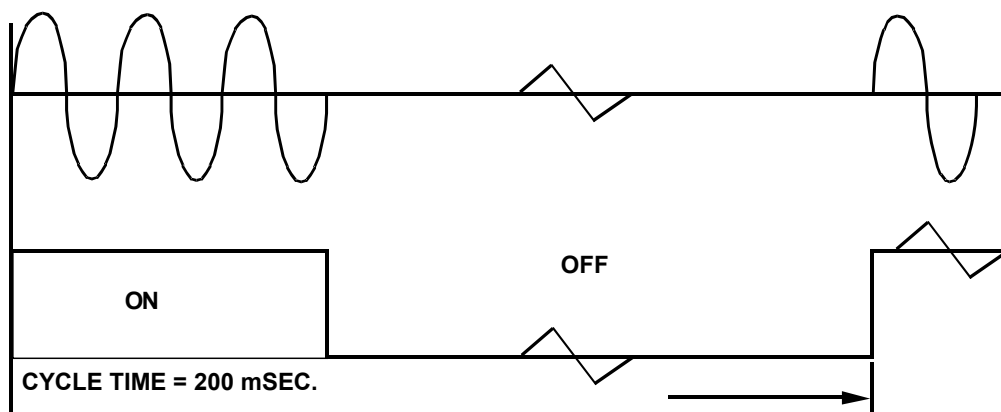

18.9 3 ϕ Zero crossing control (By TRIAC)

- Available Models : FY900 / PFY900
- OUT1: 3 ϕ SCR zero cross control
- Data Change : OUTY=0
CYT1=1

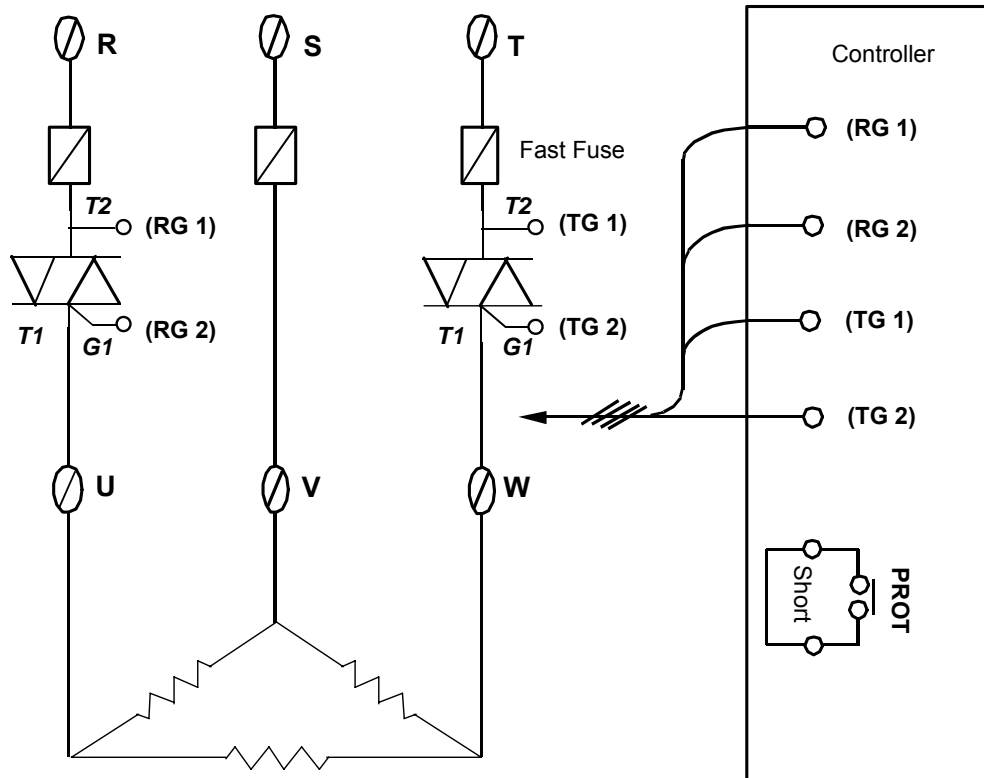

18.10 3 wires proportional motor valve control

- Available Models : FY900 / PFY900 , FY700 / PFY700
FY800 / PFY800 , FY600 / PFY600
FY400 / PFY400 , FY100 / PFY100
FY101 / PFY101
- Data Change : OUTY=3
CYT1=1 ~ 100sec.
(Manufacturing default setting “5” seconds.)
RUCY=5 ~ 200 seconds.

※After change “RUCY” the controller must be reset

1. CYT1 is the cycle time of Open / Close
2. RUCY is the 0 ~ 100% running time of motor valve

MOTOR VALVE

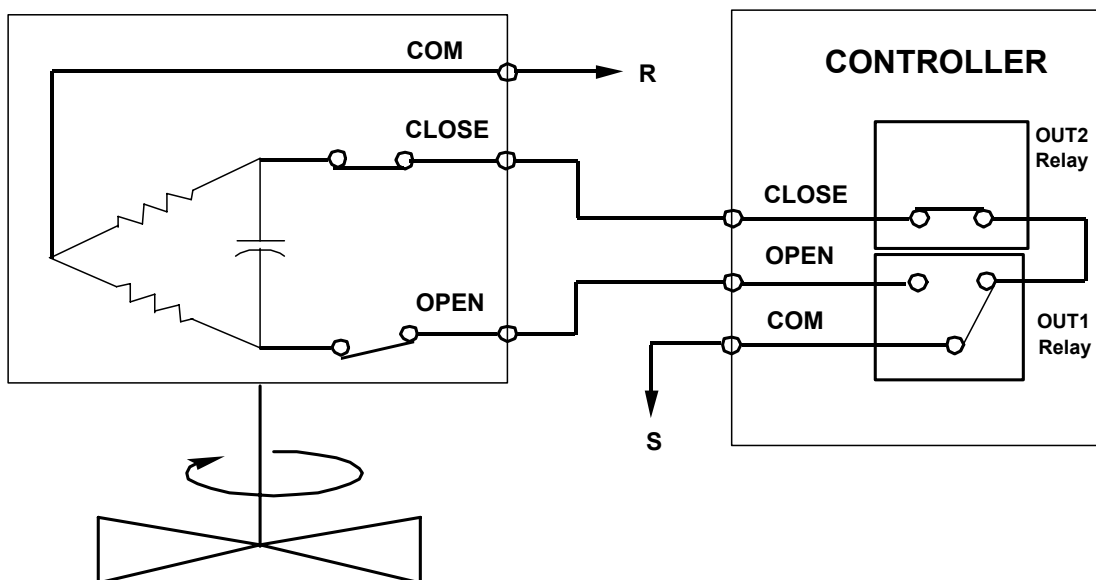

18.11 Wiring diagram of PC communication

RS232 Connection Diagram

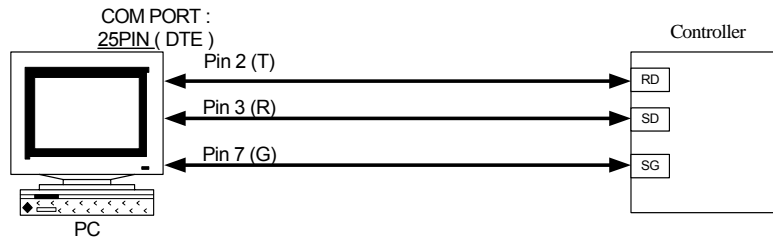
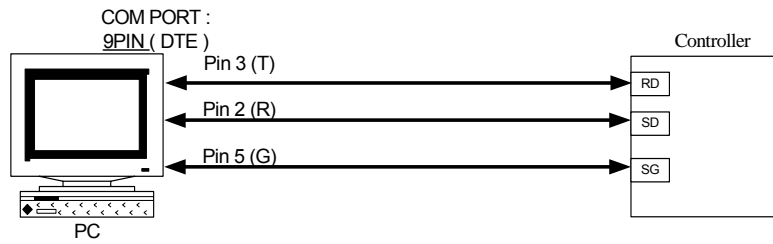

NOTE:

- 1.The length of cable be connected between controller and PC can't exceed 15 meter.
- 2.One Com Port can only be connected to one controller.
If more than one controller is connected to one Com Port , communication will be failed.
- 3.Ensure that the controller's IDNO and BAUD settings are the same with PC software's settings.
- 4.For the software communication format please refer to communication manual.

RS485 Connection Diagram

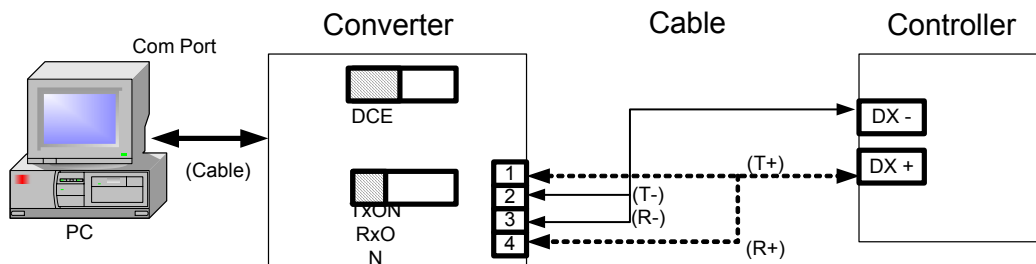

NOTE:

- 1.The length of cable be connected between Converter and Controller can't exceed 1.2 KM.
Suggestion:choose "Shielded Cable".
- 2.One Com Port can be connected up to a maximum of 30 Controllers.
- 3.Ensure that the Controller's IDNO and BAUD settings are the same with PC software's settings.
- 4.For the software communication format ,please refer to communication manual.

19. Order Information

19.1 FA Series

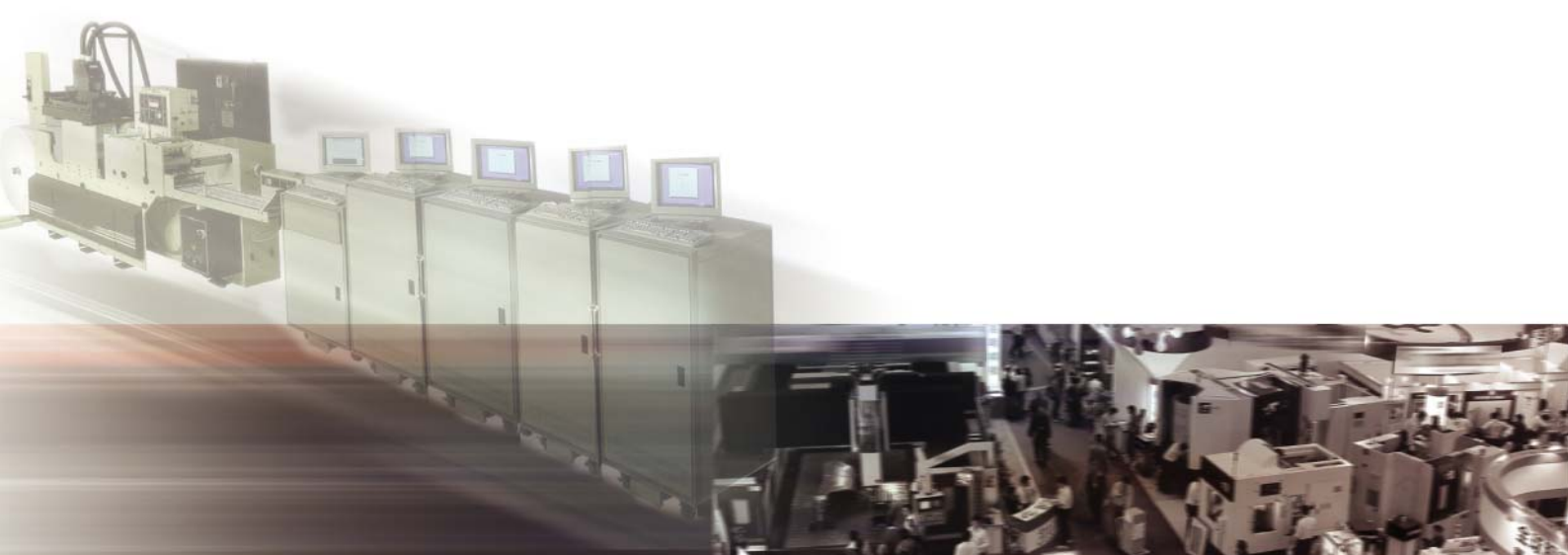

Distubor

